

Communication Satellite Systems Trends and Network Aspects



Paul Anderson
Communication Architectures Department
The Aerospace Corporation
Paul.r.anderson@aero.org
<http://www.aero.org/>

Lee Center, Caltech
13 April 2009

Communication Satellites

- Brief History by Decade
- Trends by Decade:
 - *Telephone and video relay (1960's, 1970's)*
 - *Business data services (1980's)*
 - *Broadcast services (1990's)*
 - *Mobile services (1990's)*
 - *Broadband services (2000's)*
- Network Aspects
- References:
 - *Communication Satellites*, fifth edition, by D. Martin, P. Anderson, L. Bartamian, Aerospace / AIAA Press, 2006
 - *The Advanced Communications Technology Satellite*, by R. Gedney, R. Schertler, and F. Gargione, SciTECH publishing, 2000



Communication Satellites: Benefits, Constraints

- Benefits
 - *Quickly serve large geographic areas*
 - *Easily reach mobile, rural, remote users*
 - *Provide on-demand, flexible wireless services*
- Constraints
 - *Large initial investment*
 - *Spectrum availability (regulatory constraints)*
 - *Communication capacity design challenges*
 - *Satellite reliability, longevity and flexibility*
 - *Long propagation delays*
 - *Propagation Impairments (e.g. rain fade, shadowing, multipath)*



Dimensions (1)

- Operator types
 - *Commercial, civil, defense organizations*
- Satellite communication service types
 - *Fixed point-to-point communications (trunking)*
 - *Broadcast services (point - to - area)*
 - *Mobile user services (Mobile-to-gateway, mobile-to-mobile)*
- Service areas of systems
 - *Domestic (national)*
 - *International (e.g. North America)*
 - *Global*



Dimensions (2)

- Regulatory (spectrum management)
 - *National licensing, coordination*
 - FCC, National Telecommunications and Information Administration
 - *International coordination*
 - International Telecommunication Union, an agency of United Nations
- Lifetime Cost
 - *Conceptual design, requirement definition*
 - *Spacecraft build requires 2 to 4 years*
 - *Launch cost and launch schedule constraints*
 - *Ground terminals and infrastructure*
 - *Operational costs (now ~15 years)*
 - *Construction and launch costs are a function of spacecraft mass, power and complexity*



Communication Satellite Payload Types

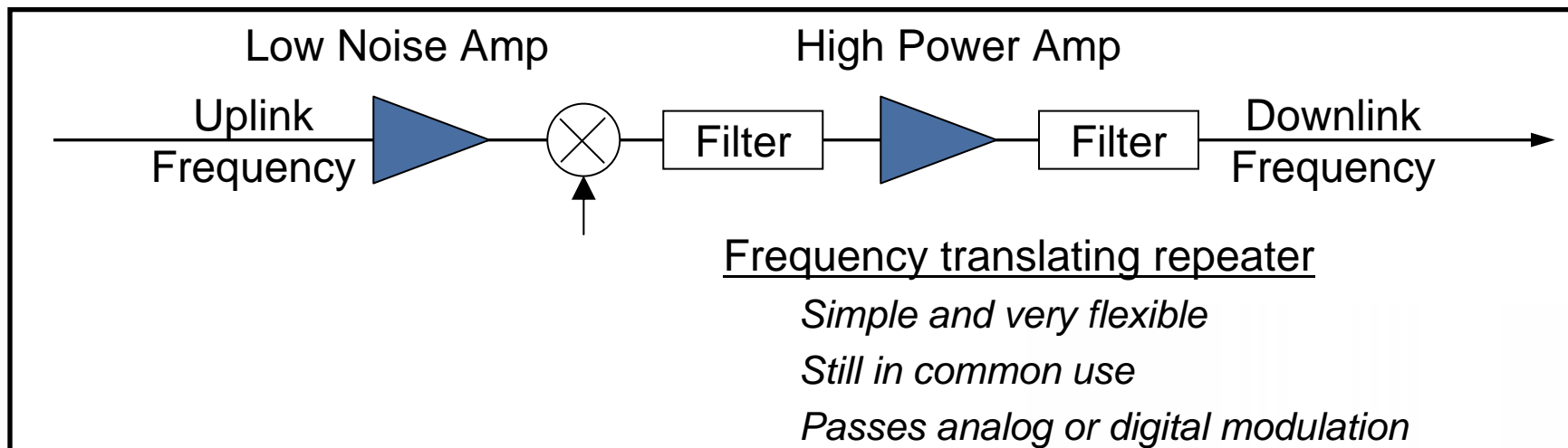
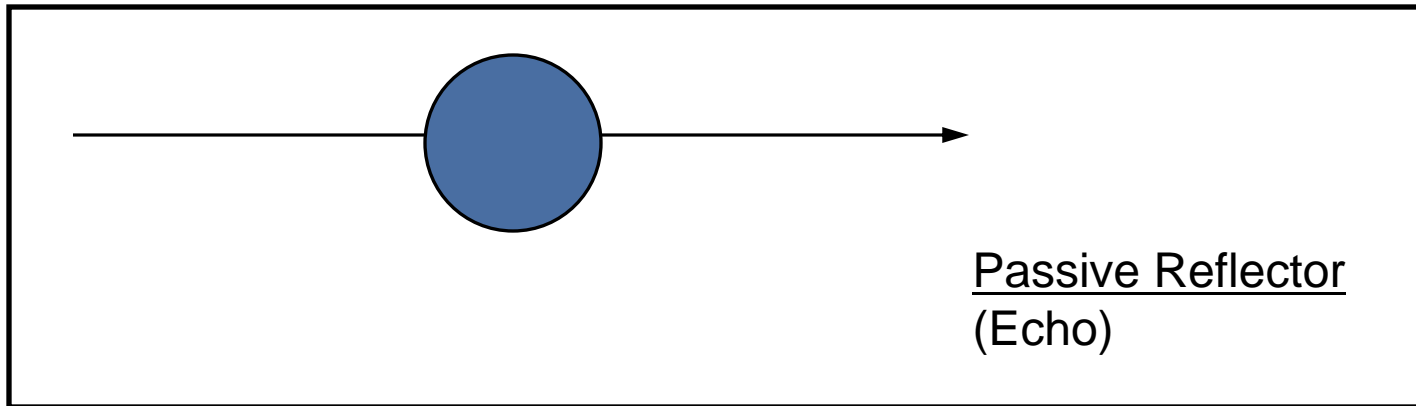

1960's

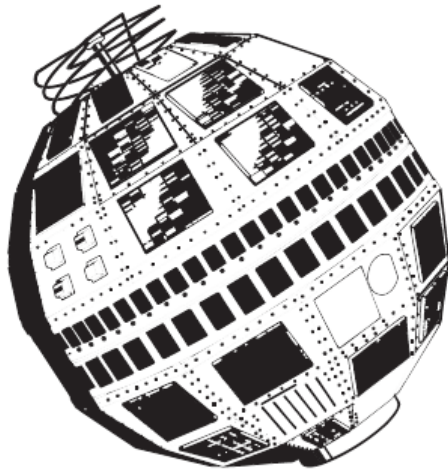

Telstar 1, 1962

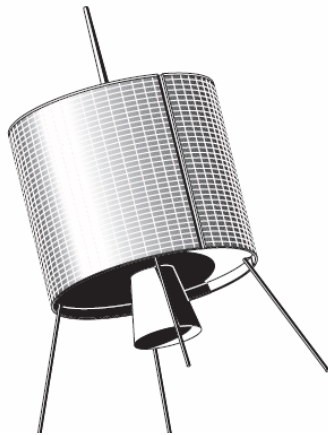

Early Bird (Intelsat I) 1965

Typical allocated frequency band:
6 GHz uplink, 4 GHz downlink

Typical Uses:
Simple relay of video, audio

Spacecraft (typical characteristics):

~ 100 kg, ~ 100 W

Frequency translating repeater

~ 50 MHz bandwidth

Spin stabilized

2 to 4 year design life

Transmission: Analog FM

Experimental and early commercial use satellites



1960's

Telephone relay:

Fixed point-to-point links

No on-board switching or routing

No on-board processing

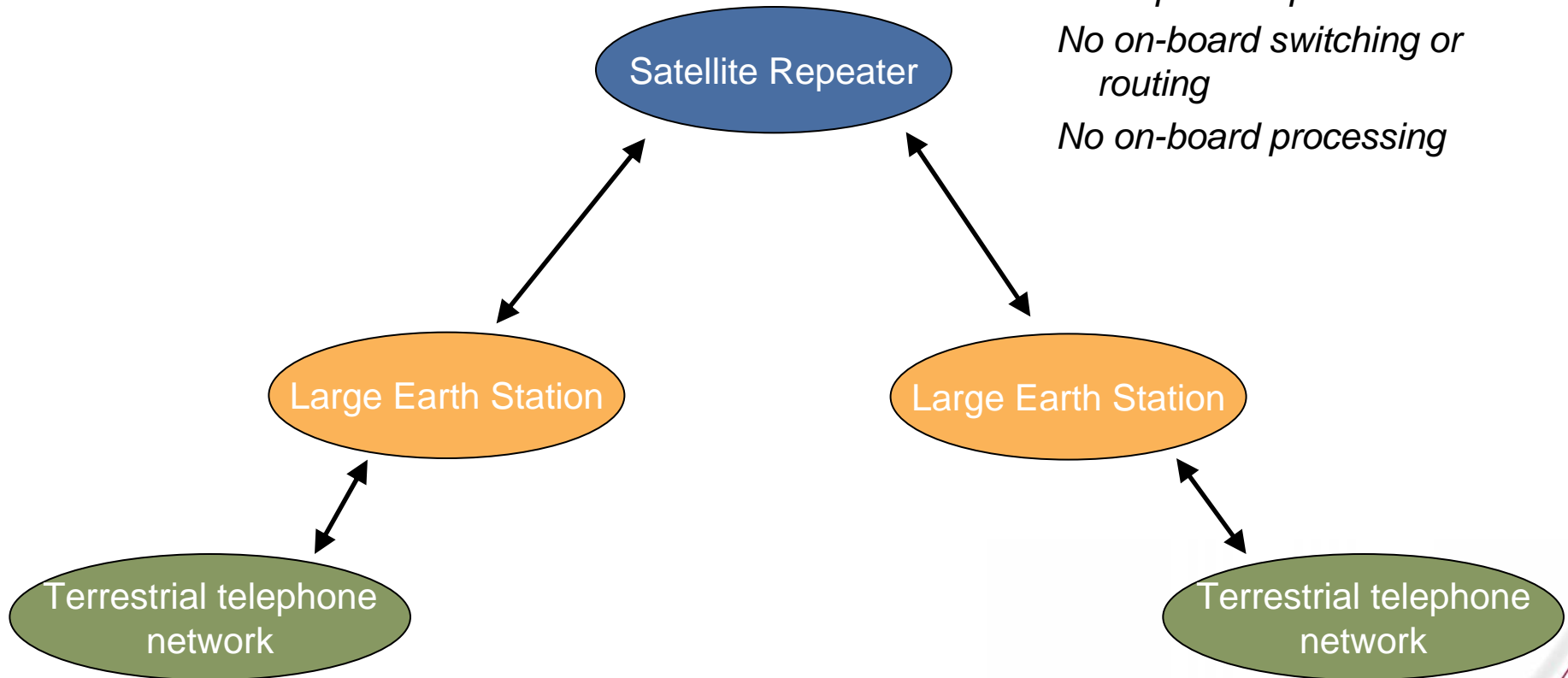

Basic long-distance relay



1970's

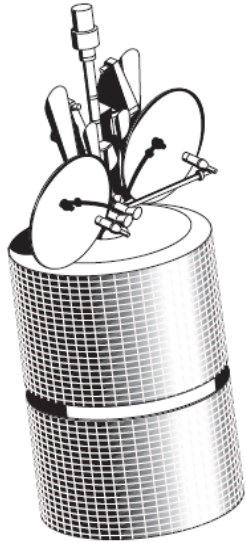

Intelsat IV
8 Launched from
1971 - 1975

Typical allocated frequency band:
6 GHz up, 4 GHz down

Typical Uses:
*Telephone trunking
Video distribution*

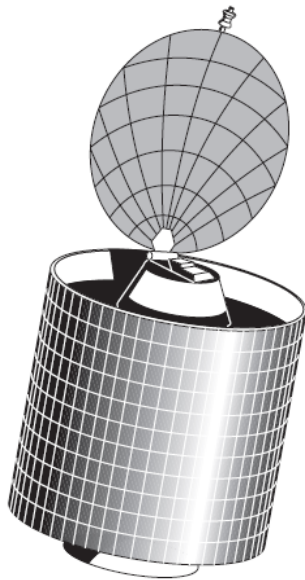

Anik A
3 Launched from
1972 - 1975

Spacecraft (typical characteristics):
*~ 300 to 800 kg
~ 200 to 1000 W
~ 400 to 500 MHz bandwidth
Frequency translating repeater
Spin stabilized, some 3-axis
Up to 7 year design life*

Transmission: Analog FM



1970's

Telephone and Video relay:

Fixed point-to-point links

No on-board switching or routing

No on-board processing

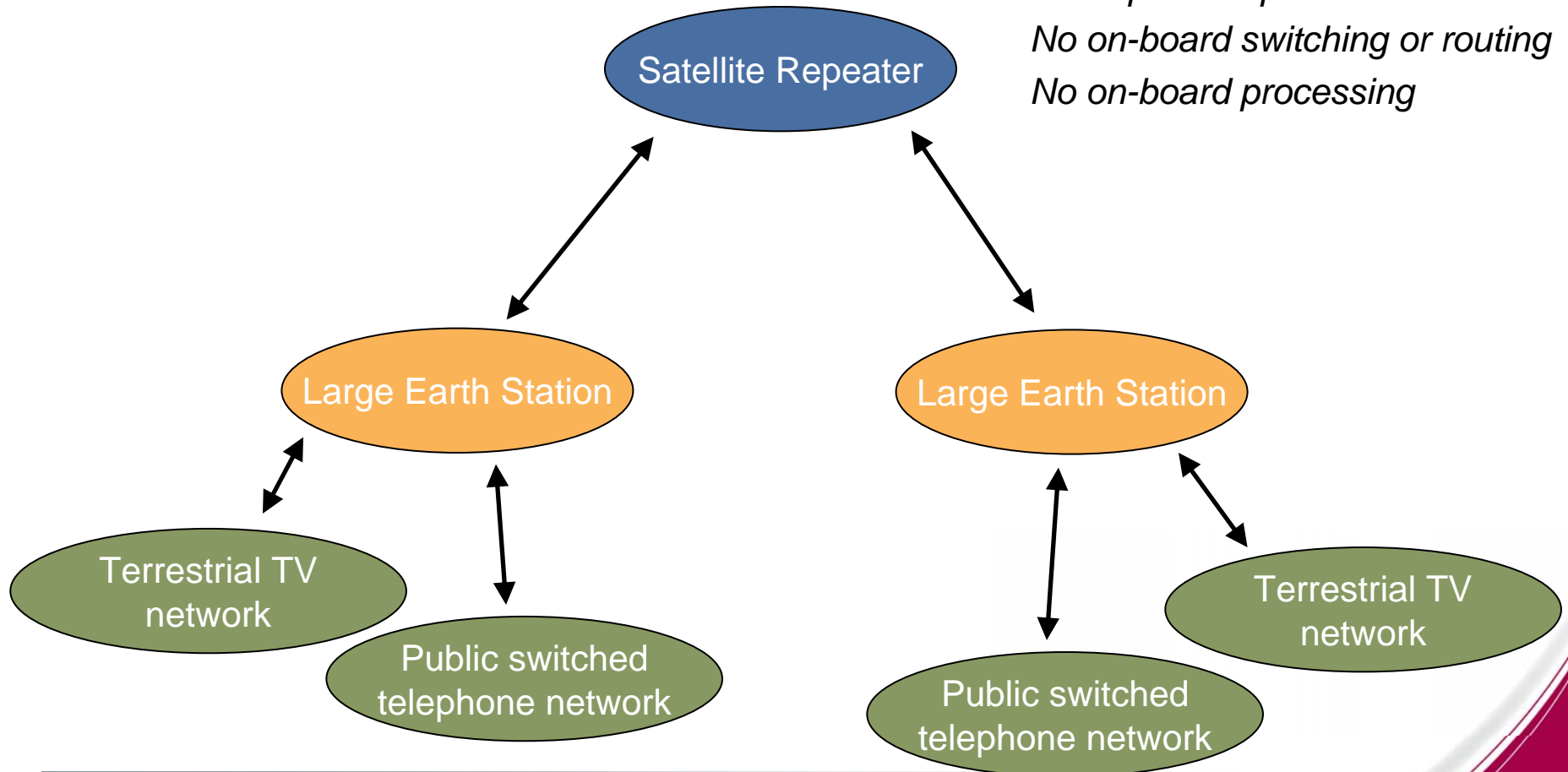

1980's



Satellite
Business Systems
(SBS)
5 Launched from
1980 - 1988

Typical allocated frequency bands:

6 GHz up, 4 GHz down

14 GHz up, 11 GHz down

Typical Uses:

Telephony

Video, data distribution

Spacecraft:

~ 500 to 1000 kg,

~ 1 to 8 kW

~ 800 to 1600 MHz bandwidth

Frequency translating repeater

Spin stabilized, some 3-axis

Up to 10 year design life

Transmission:

Analog FM, Digital (TDMA)

Intelsat V, 9 launched 1980 - 1984

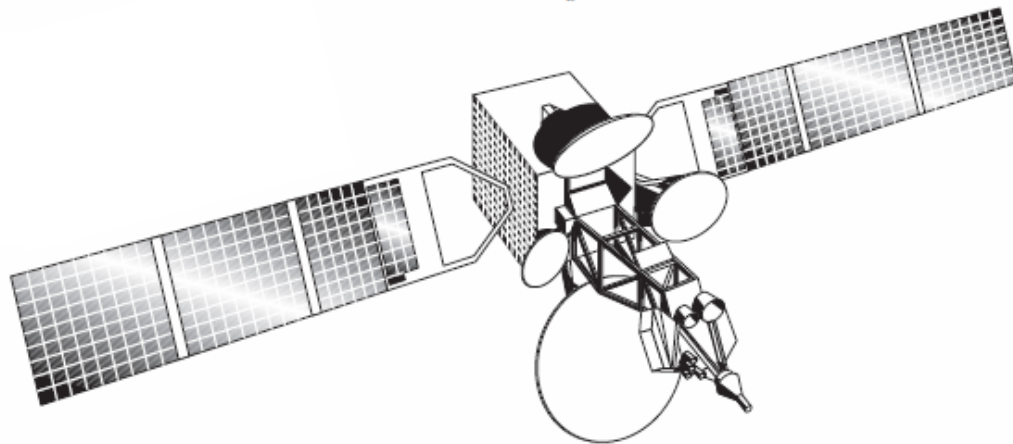

1980's

Business Data Services:

Fixed point-to-point links

VSAT terminals to data hubs

Time division multiple access

Switching on the ground

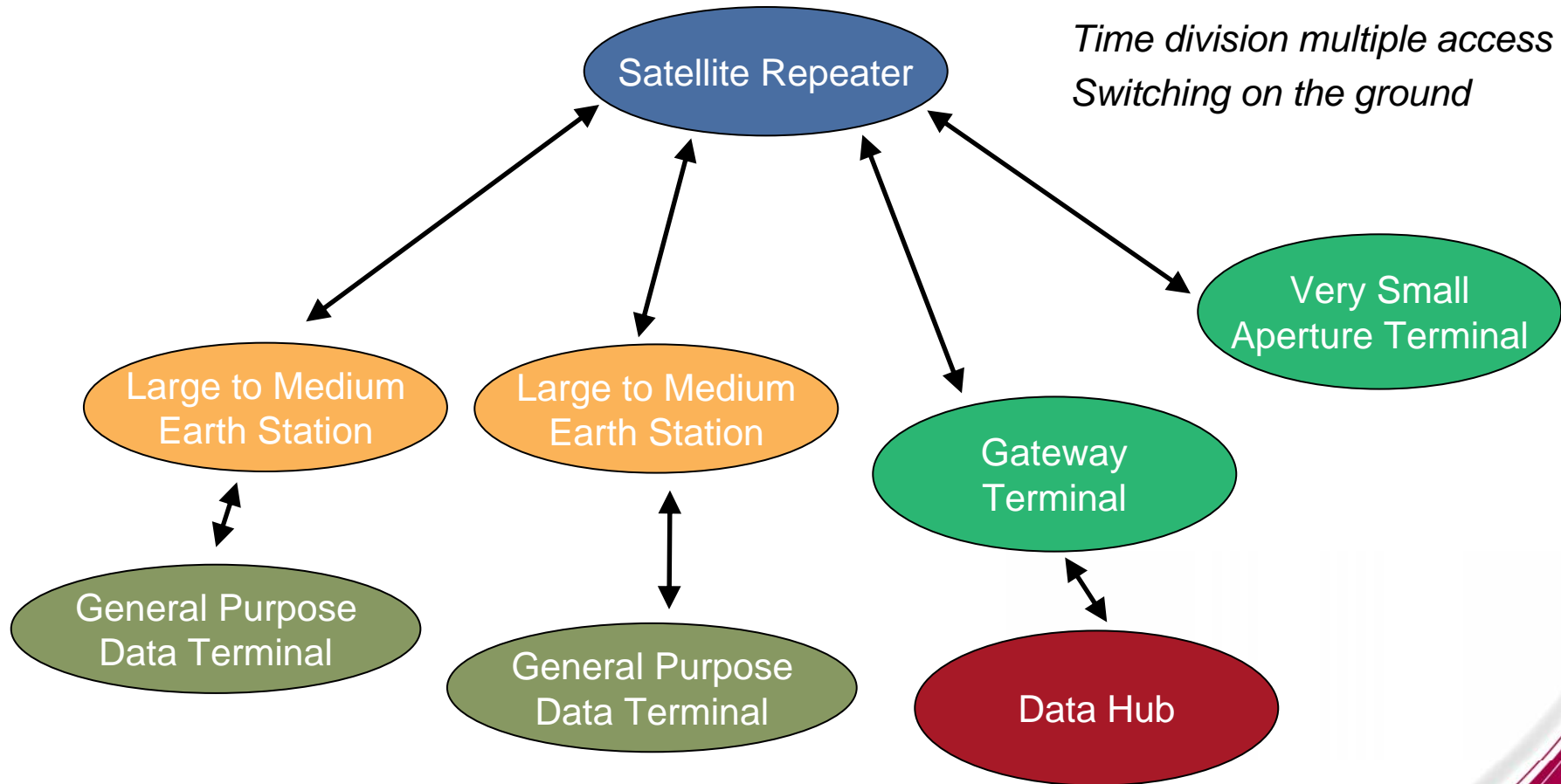



1990's

DIRECTV 1, 2, 3
Launched from
1993 - 1995

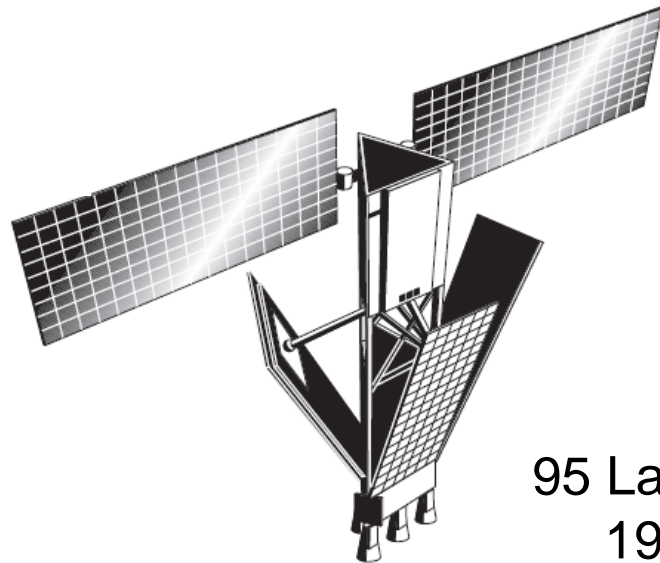

Iridium
95 Launched from
1997 - 2002

Typical allocated frequency bands:

1600 MHz (mobile users)

6 GHz up, 4 GHz down

14 GHz up, 11 GHz down

17 GHz up, 12 GHz down

Typical Uses:

Video, data distribution

Video broadcasting

Mobile Telephony

Spacecraft:

~ 600 to 3000 kg

~ 1 to 10 kW

~ 1600 to 3000 MHz bandwidth

Primarily 3-axis stabilized

Satellite lifetime ~15 years

Iridium produced by production line

Transmission:

Primarily digital



Broadcast Satellite Networks:

Point to multipoint broadcasting

Source encoding (MPEG)

Simple satellite repeater

TDM stream is packet-based

1990's

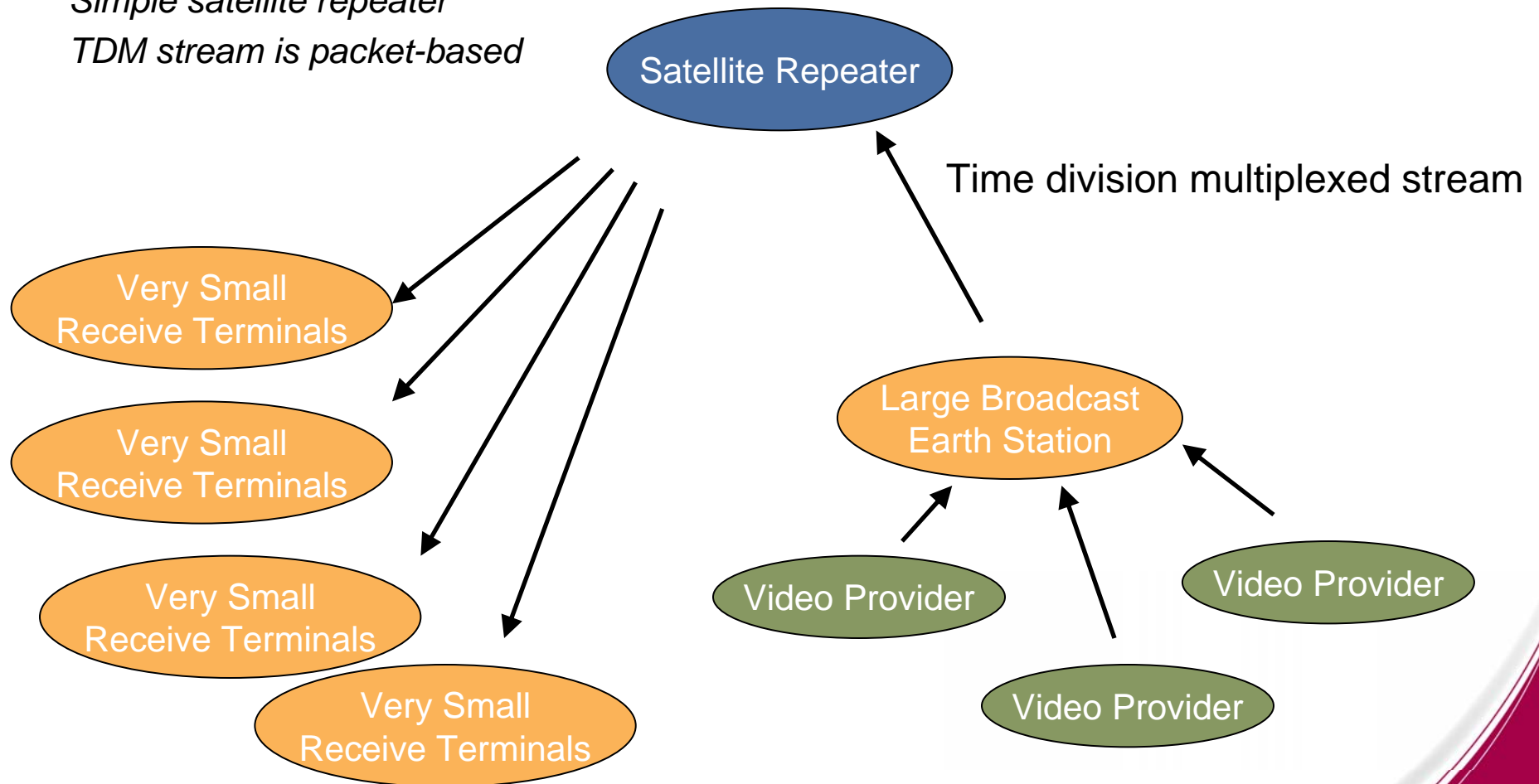

Direct Broadcast Satellite Architecture

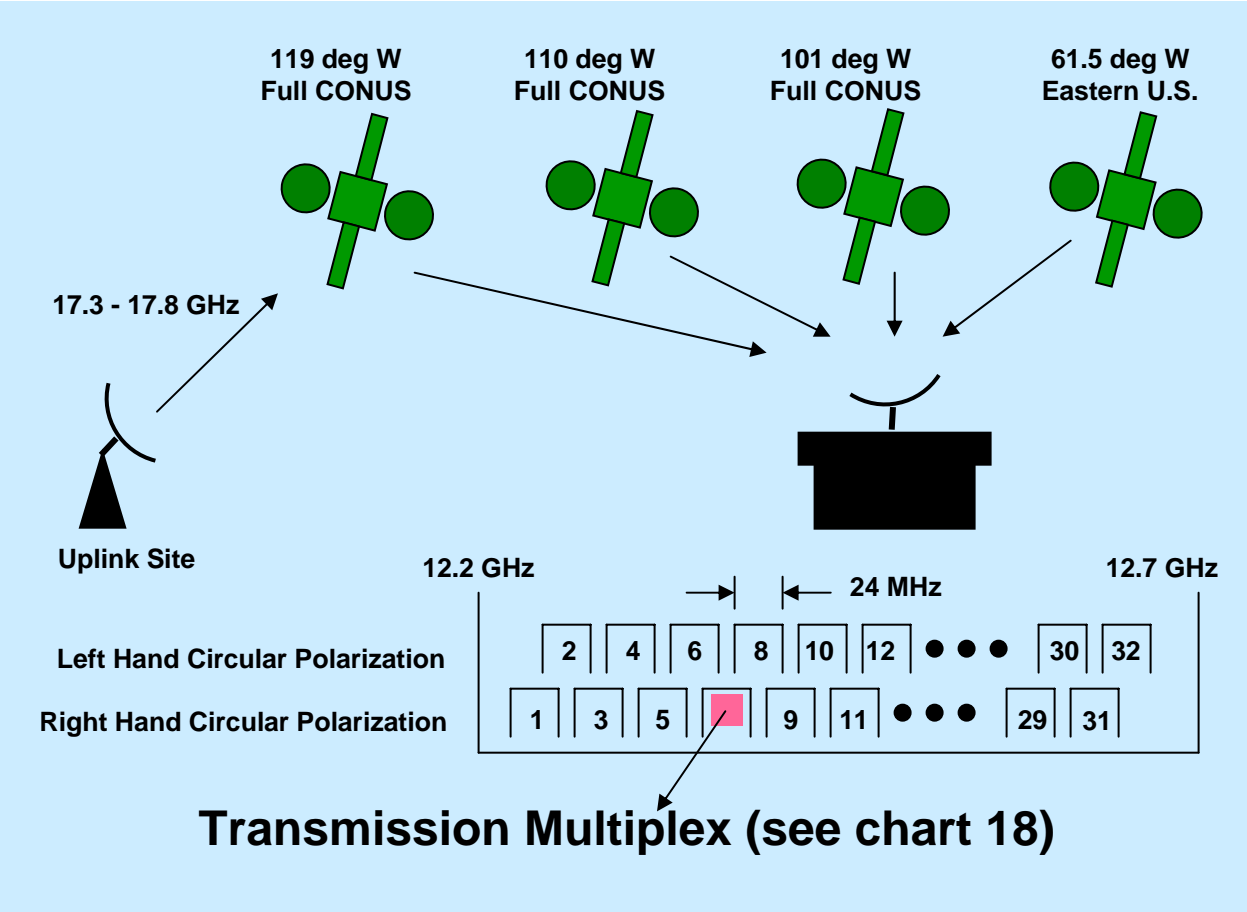

Typical DIRECTV Coverage Pattern

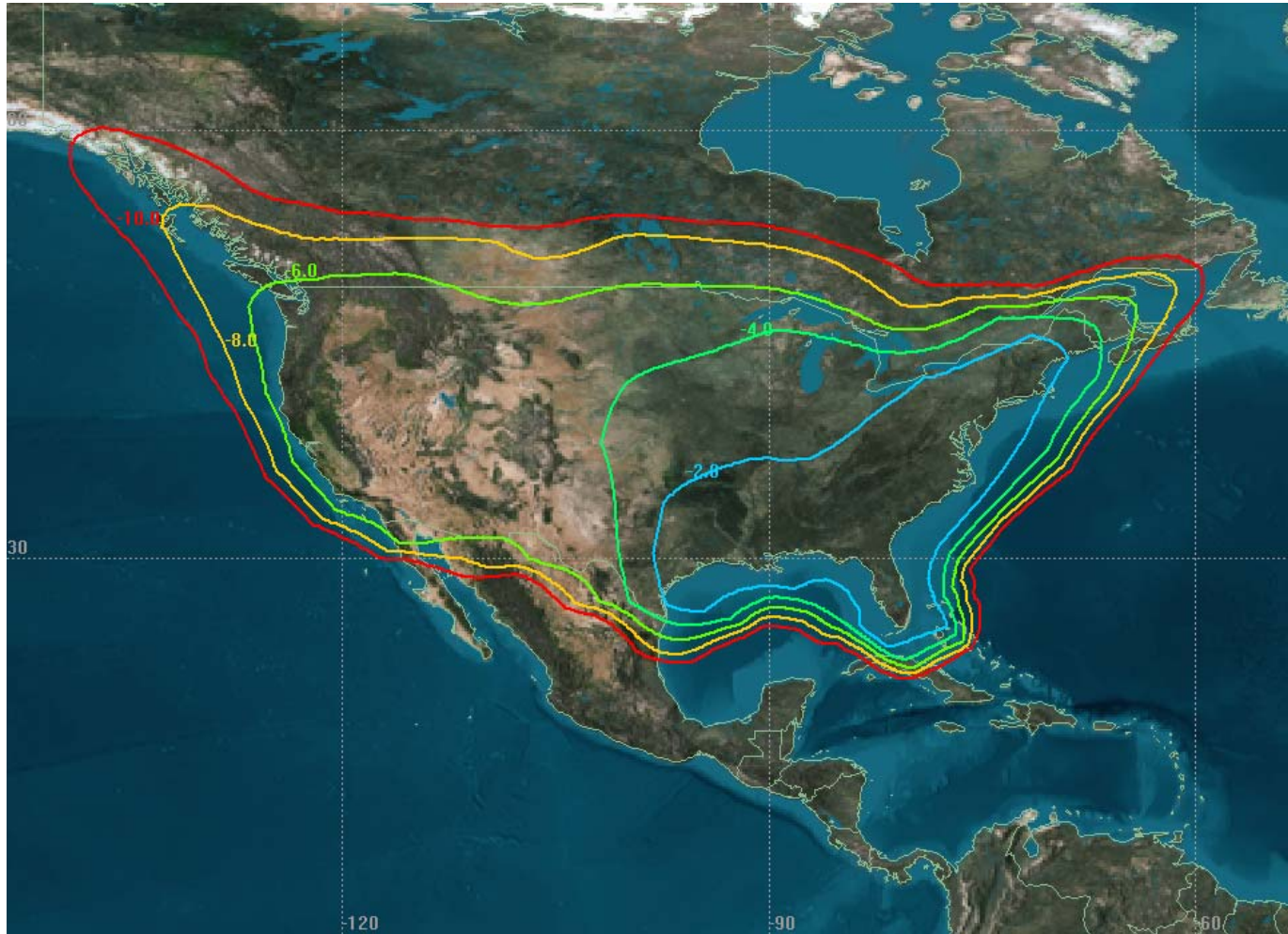

Reprinted courtesy of the FCC

DIRECTV 9S:

Antenna gain, dB

National beam

Downlink

12.5 GHz

2 dB contours

Location: 101° W

From: FCC public filing information, displayed using Satellite Tool Kit Software



Broadcast: Physical Layer Typical Characteristics

- QPSK modulation with concatenated forward error correction code (DVB S1 standard)
 - *Convolutional inner code*
 - *Rates of 1/2, 2/3, 3/4, 5/6, and 7/8*
 - *Reed Solomon block outer code (240, 188, T=8)*
 - *Symbol rate not fixed (flexibility)*
 - *Typically 20 Msymbols/sec*
 - *Typical information rate = 26.1 Mbps (5/6 code)*
- Typical spacecraft downlink parameters
 - *200 to 240 watt TWTA*
 - *24 MHz wide transponder*
 - *Effective Isotropic Radiated Power (EIRP)*
 - *$EIRP = \text{Transmitter power} \times \text{antenna gain}$*
 - *~ 48 dBw to ~54 dBW depending on rain zone*



Broadcast Satellite Transport Layer

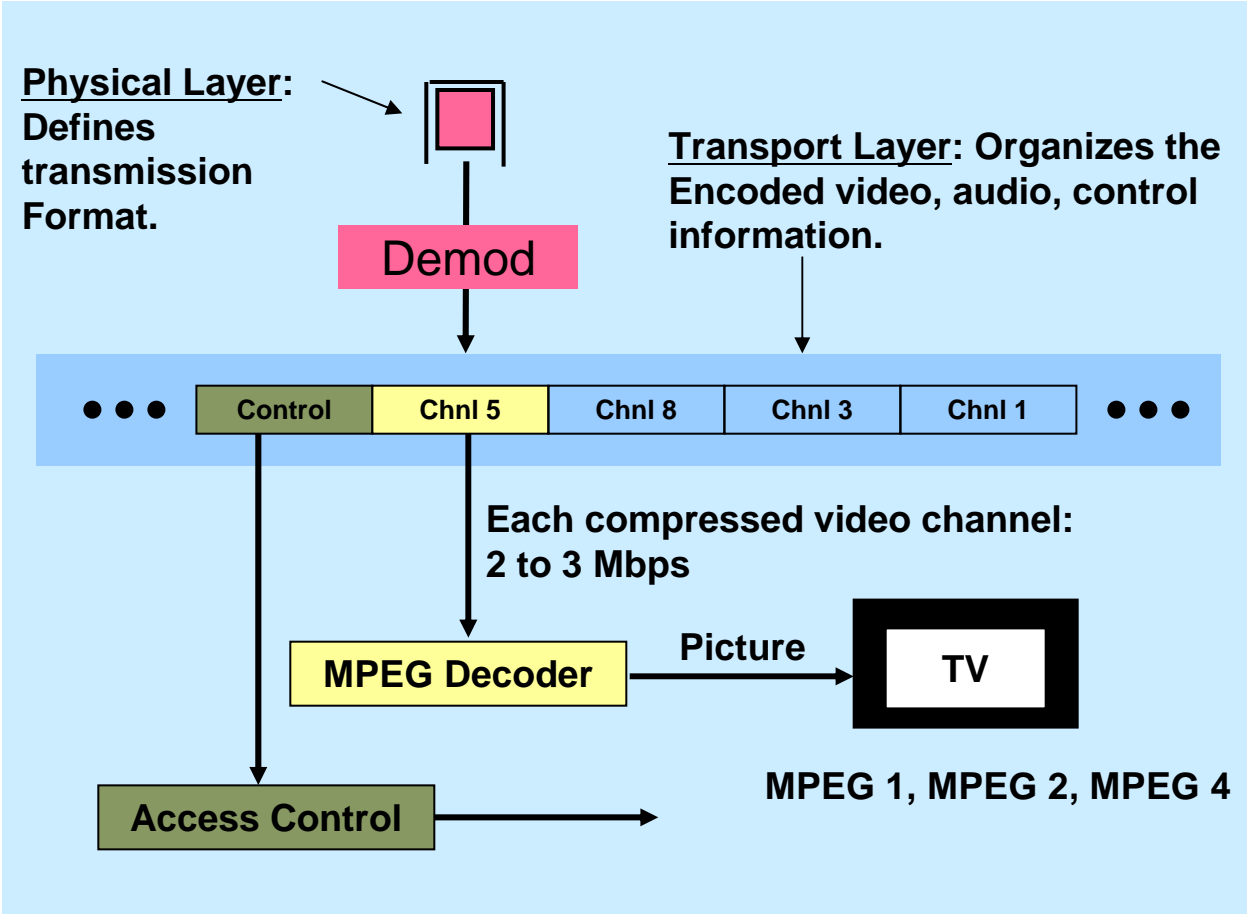

1990's

Mobile Satellite Networks

e.g. Iridium, Thuraya, Inmarsat
Video, data traffic to/from mobile terminals
Satellite payload switches calls to gateways or crosslinks

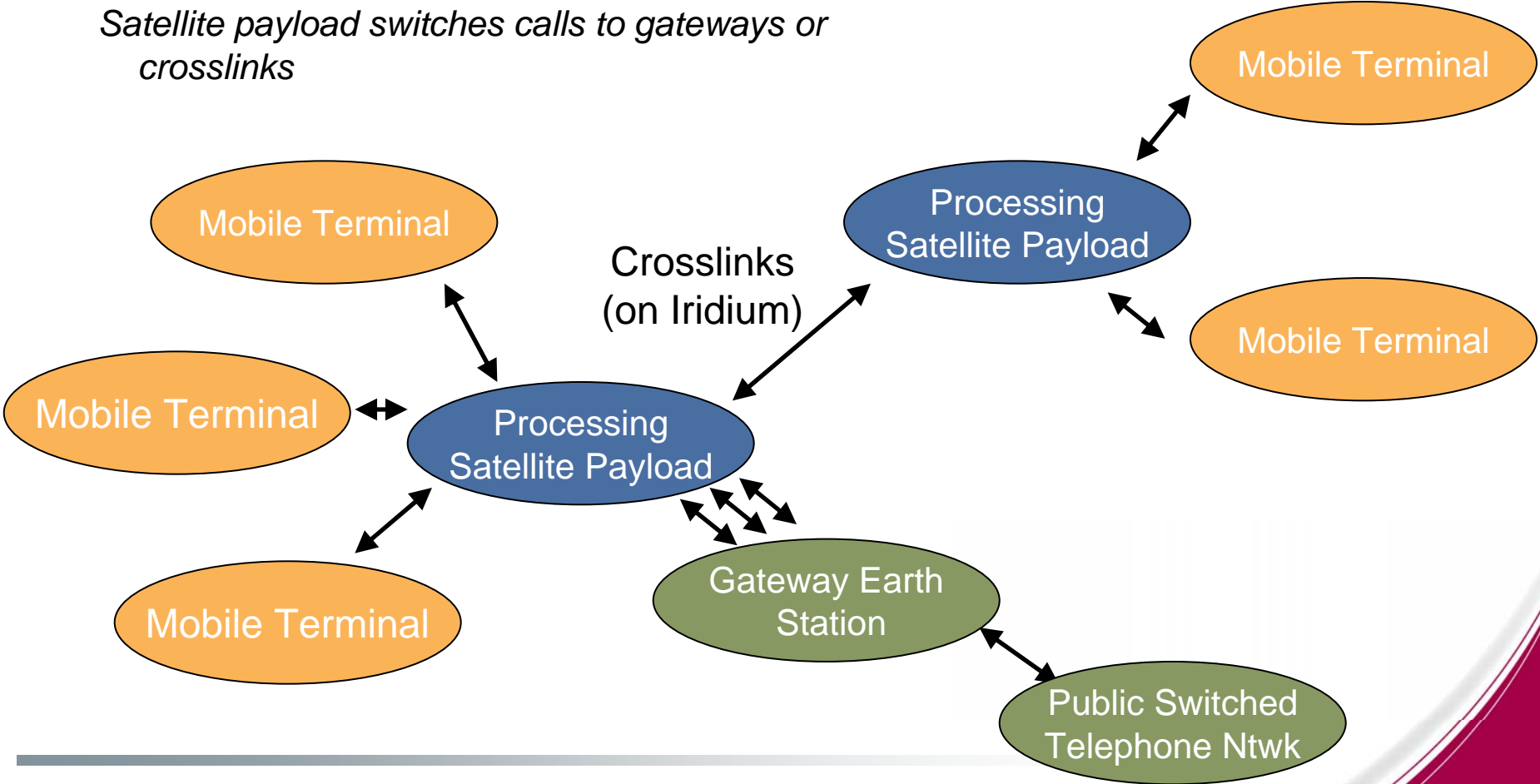

Thuraya Mobile Services Satellite

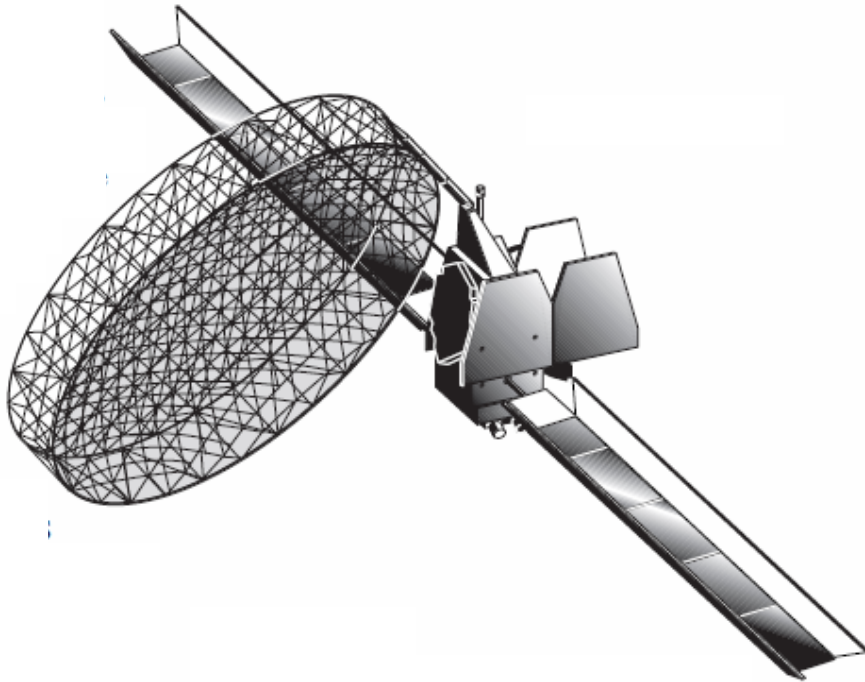

- Provides mobile telephone services to Asia, Europe, North Africa
- 3 launched between 2000, 2008
- Antenna (12.2 x 15.8 m) forms up to 300 beams in 1525 to 1559 MHz & 1626 to 1660 MHz bands
 - *Serves mobile terminals*
- Mobile terminals use GSM standard (Global System for Mobiles)
- Services: Voice, data, fax, messaging at up to 9.6 kbps



2000's

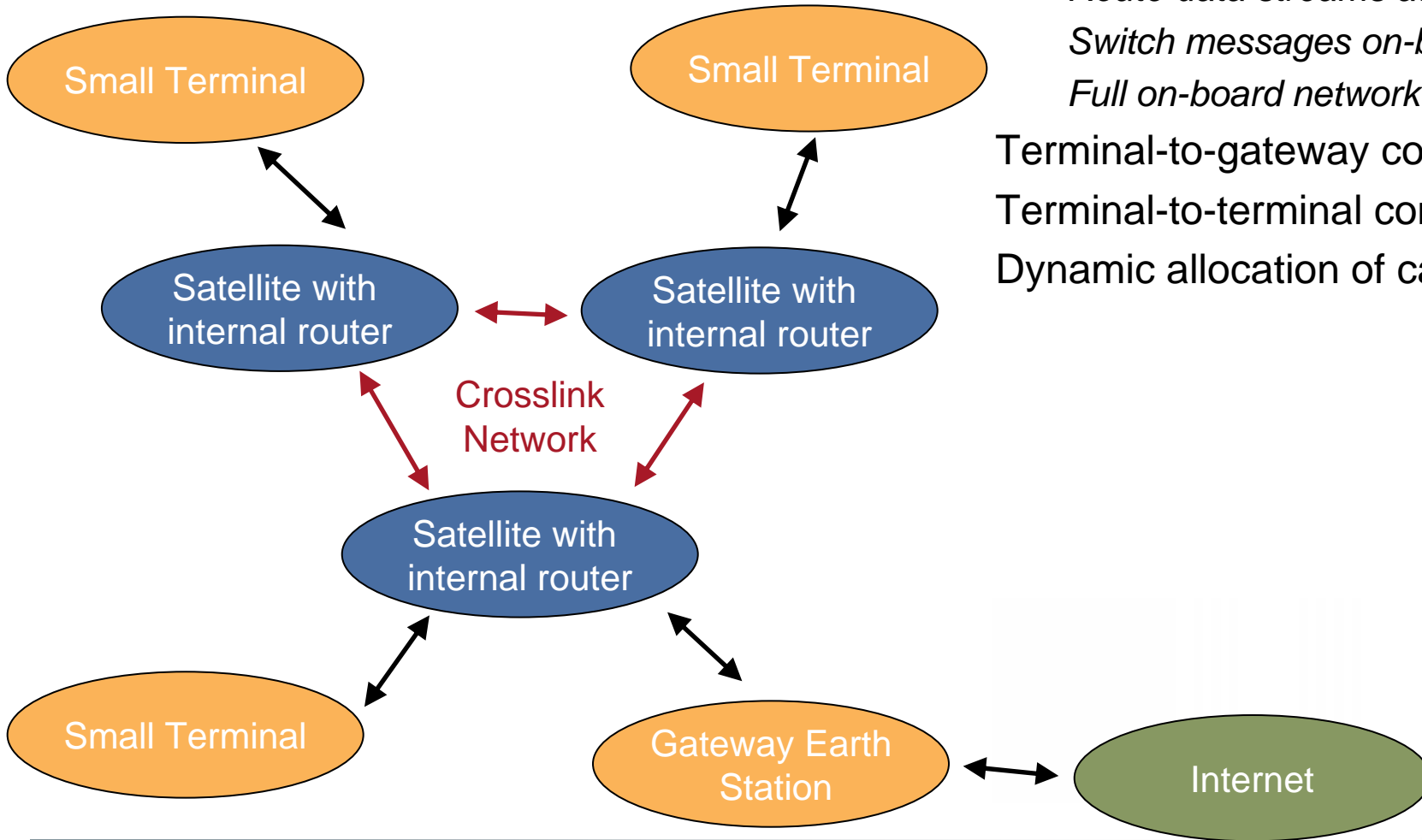

Broadband Data Services:

Various flavors

Route data streams at IF

Switch messages on-board

Full on-board network router

Terminal-to-gateway connection

Terminal-to-terminal connection

Dynamic allocation of capacity



Simple Repeater with IF Switch

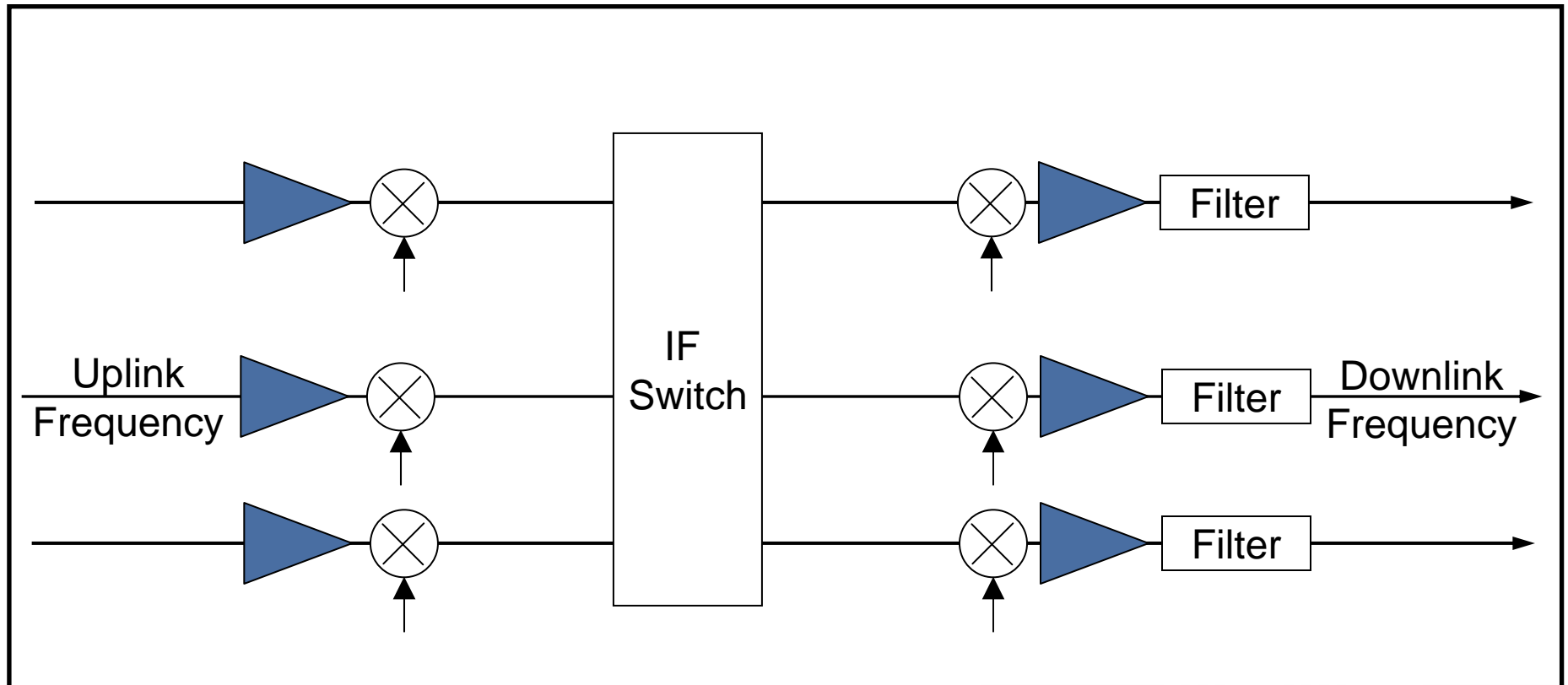

Switch at IF, uplink noise propagates to downlink

Examples: Anik F2, UHF Follow-on, DSCS, Intelsat



Partial Processing Repeater

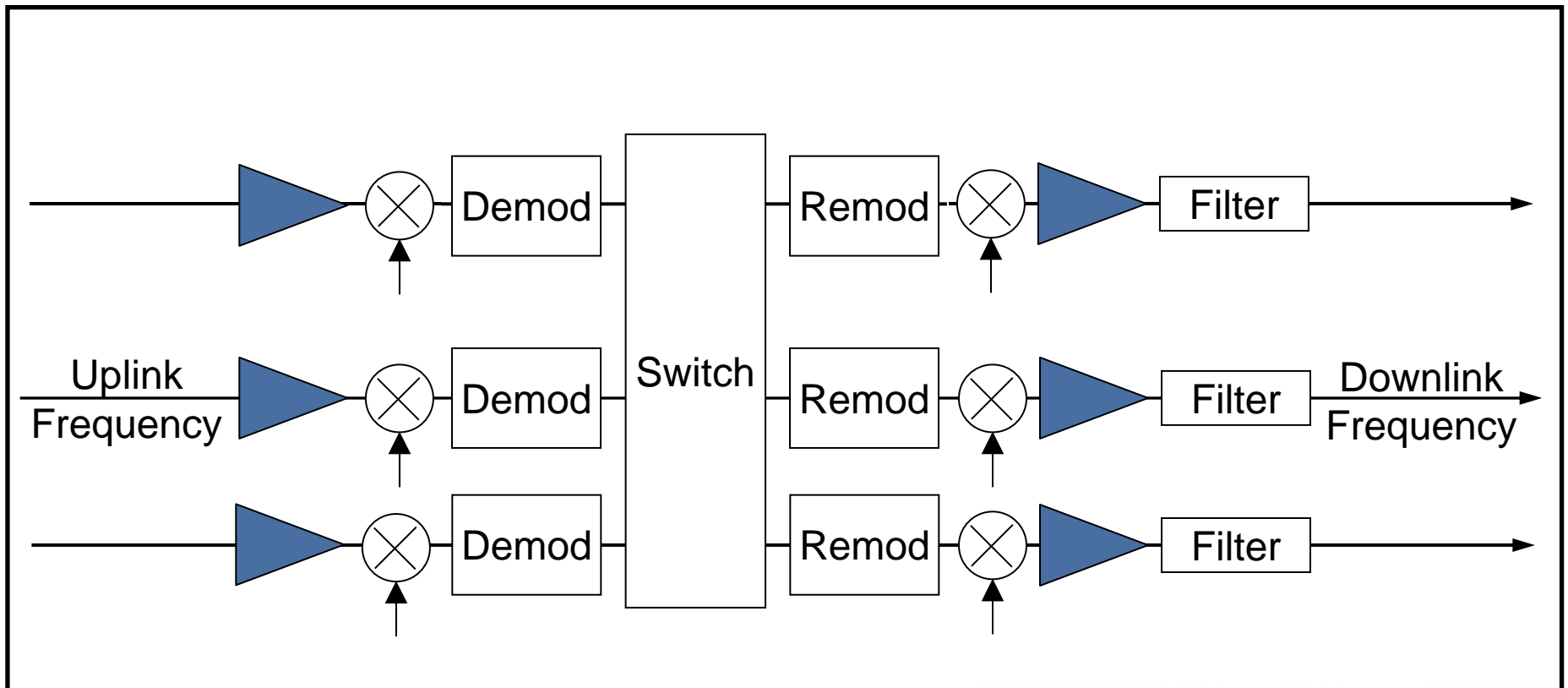

Switch at baseband, uplink noise does not propagate to downlink

Examples: Milstar, Advanced EHF



Full Processing Repeater

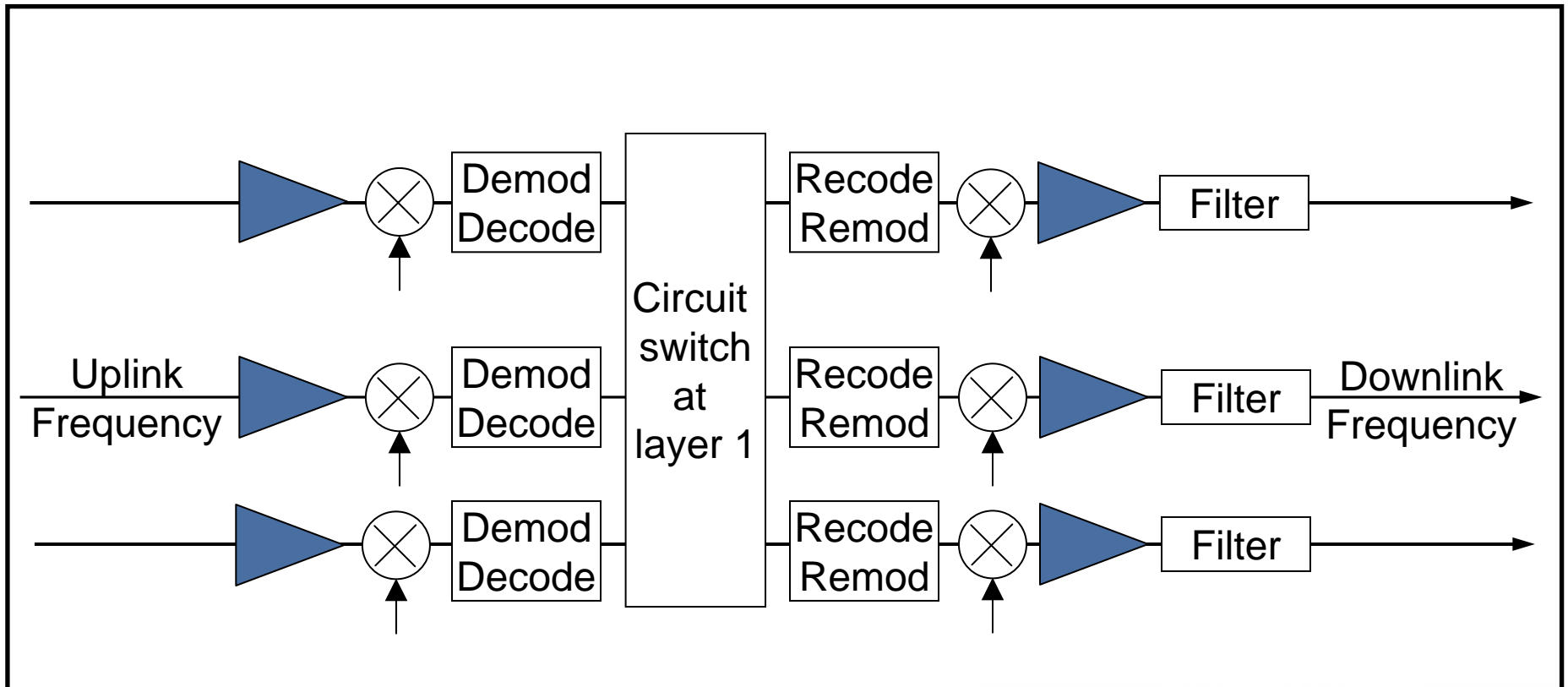

Uplink noise does not propagate, corrected uplink errors do not propagate



'Network' Processing Repeater

Examples:

*Transformational Communications
Future NASA concepts*

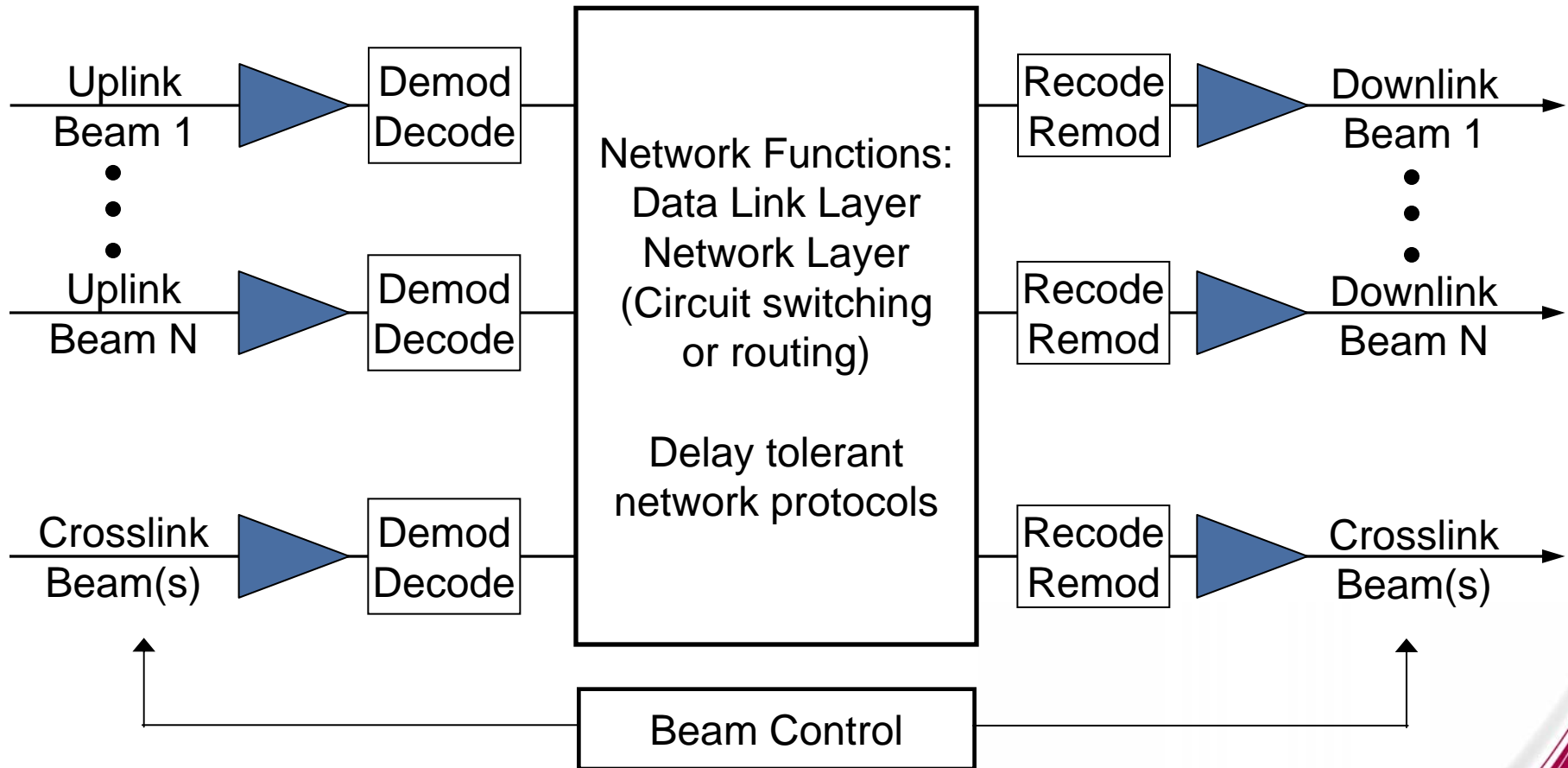

Include beam control, switching from uplinks / crosslinks to downlinks / crosslinks



Advanced Communications Technology Satellite (ACTS)

- Developed by NASA
- Launched in 1993
- Demonstrated high capacity communications

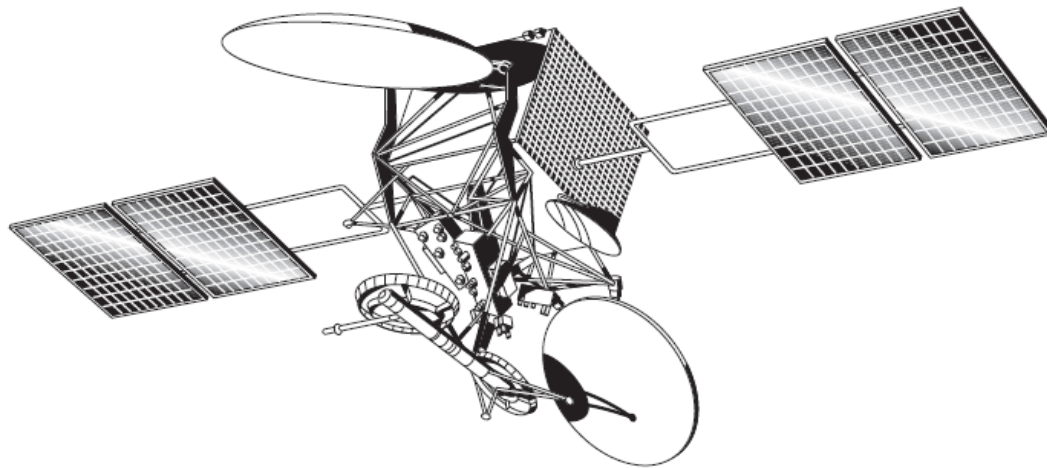

- *Multi-beam agile antenna*
- *High capacity IF switch matrix*
- *Baseband processor*
- *TDMA network*
- *Demonstrated compatible ground terminals*
- *Experimented with modifying network and application-layer protocols*



ACTS Payload Block Diagram

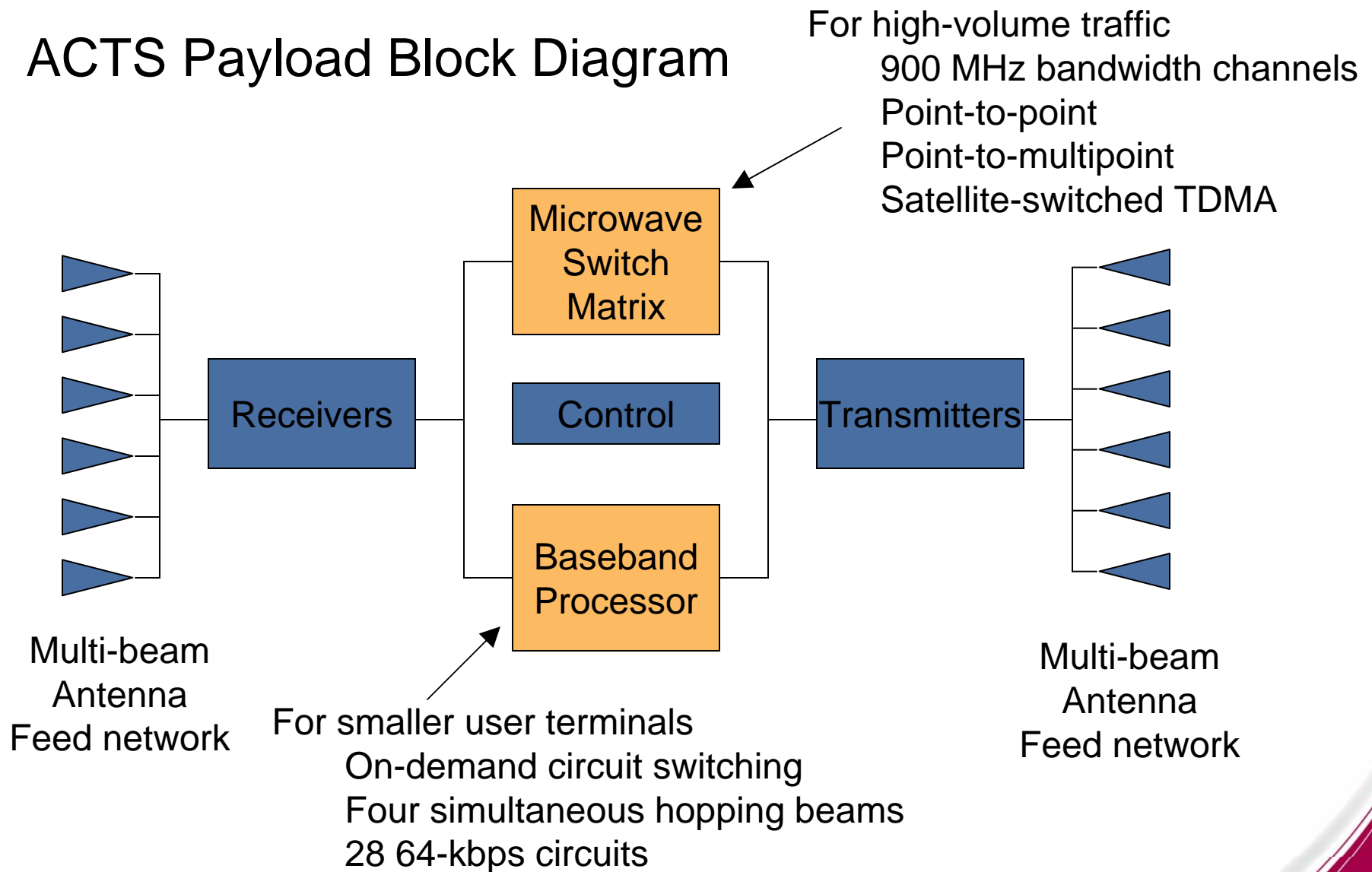

2000's

Anik F2
Launched 2004

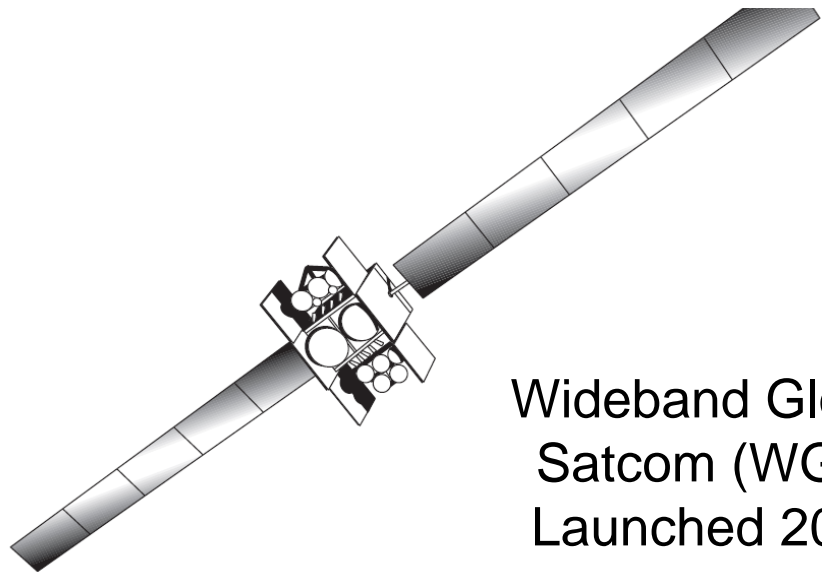
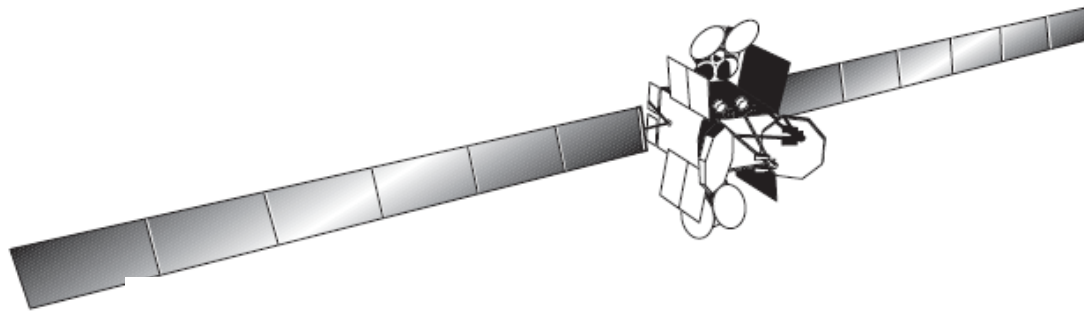

Wideband Global
Satcom (WGS)
Launched 2007

Typical Allocated Bands:

1600 MHz (mobile users)

6 GHz up, 4 GHz down

14 GHz up, 11 GHz down

17 GHz up, 12 GHz down

28 GHz up, 18 - 20 GHz down

Typical Uses:

General data services

Video, audio, data broadcasting

Mobile Telephony

Spacecraft:

~ 1000 to 4000 kg

~ 2 to 18 kW

~ up to 7250 MHz bandwidth

3-axis-stabilized dominates

Transmission:

Digital, increasing efficiency



Anik F2 Communication Repeater Block Diagram

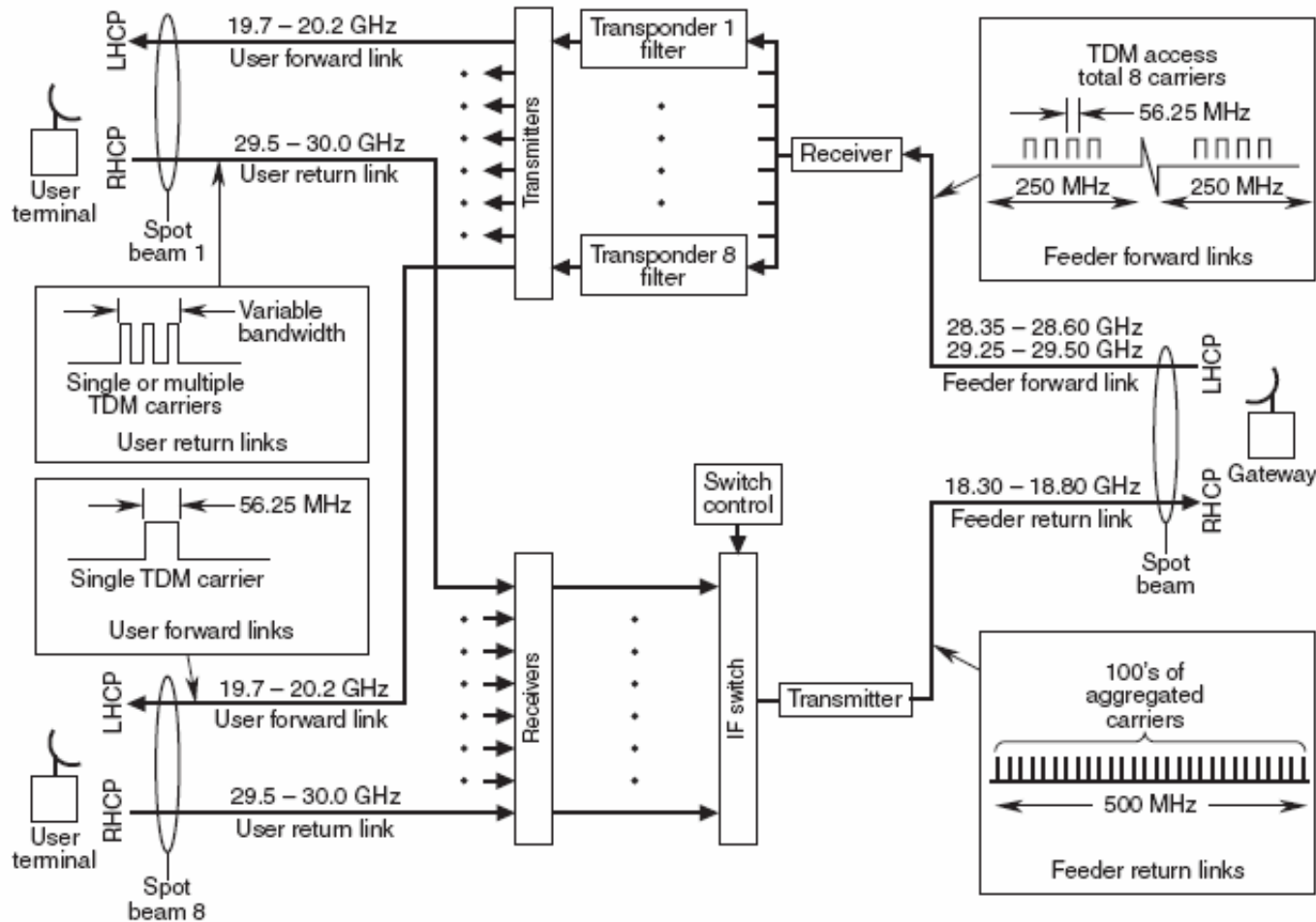

From: *Communication Satellites*, fifth edition, D. Martin, P. Anderson, L. Bartamian



Anik F2 Spot Beam Laydown

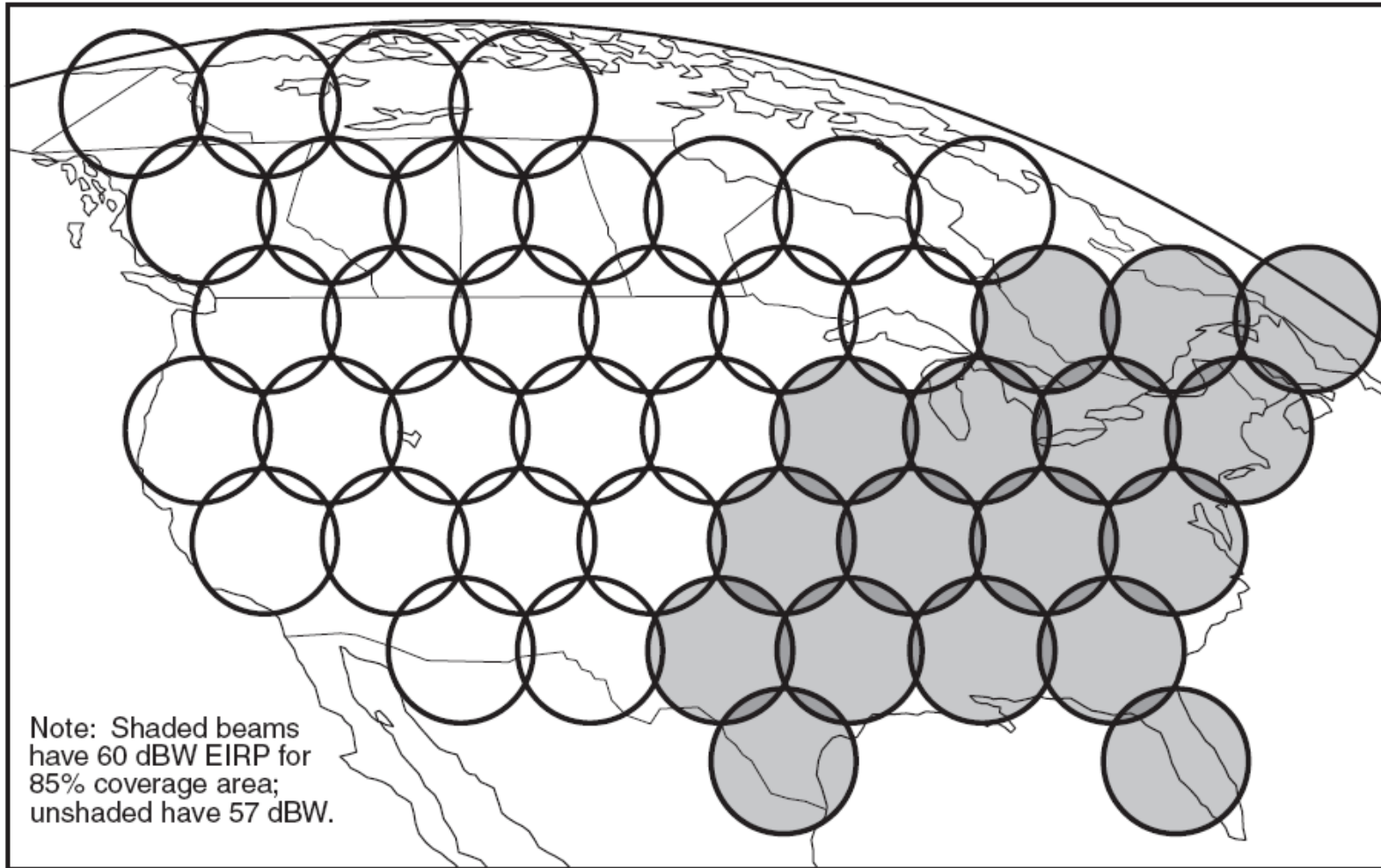

From: *Communication Satellites*, fifth edition, D. Martin, P. Anderson, L. Bartamian



Future Networked Satellite Payloads

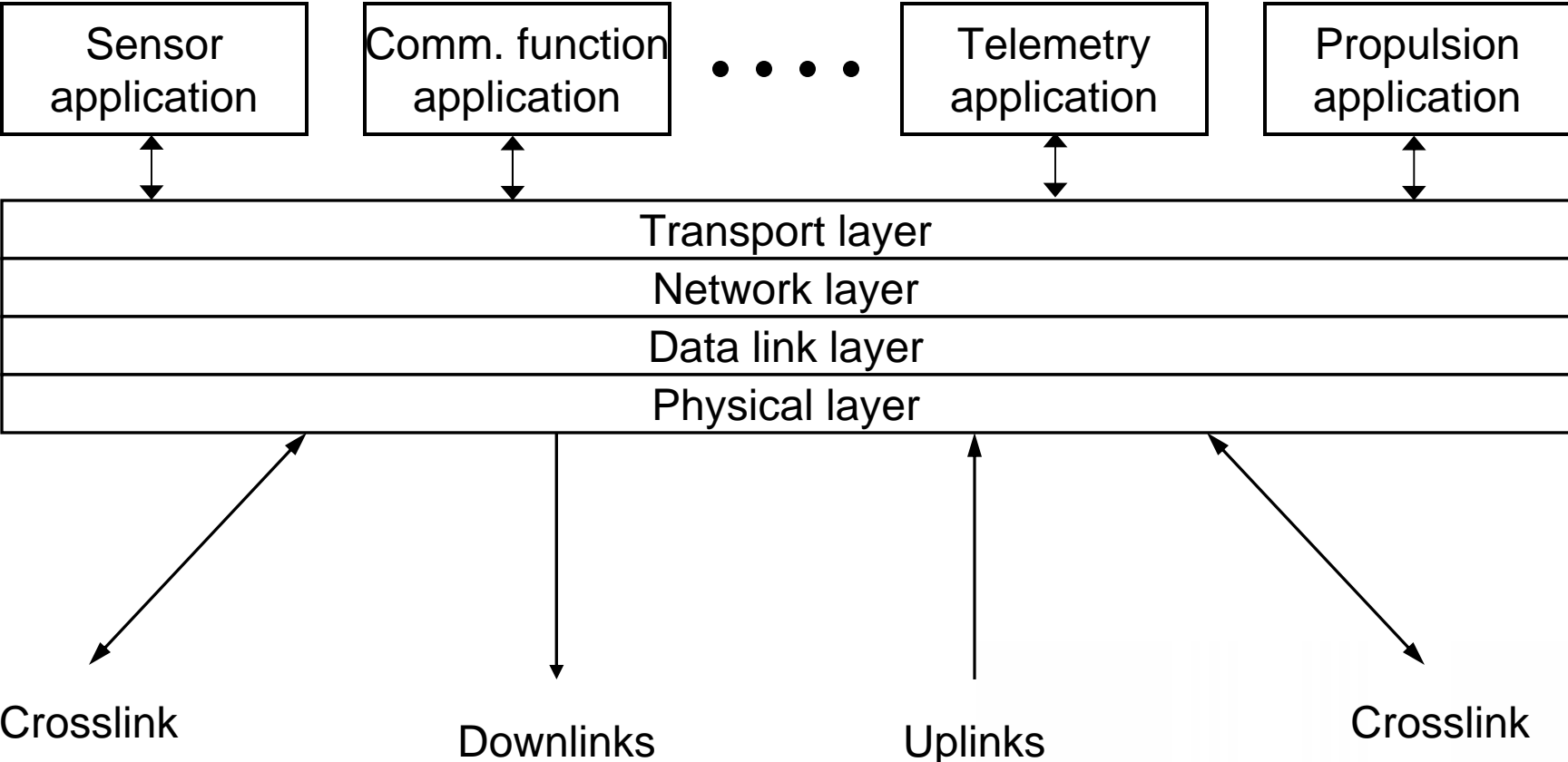

Satellite Network Research Challenges

- Traffic Model Refinements
 - *Traffic models over wireless networks of interest*
 - *Space nodes are sparse*
- Delay-tolerant protocols at the link layer, transport layer
 - *One-way propagation delay is ~ 120 ms to geosynchronous orbit*
 - *Delay-bandwidth product*
- Atmospheric propagation effects
 - *Rain fades over 10's seconds to minutes*
- Incorporation of ad-hoc mobile user networks
 - *How do these efficiently interface to a satellite network?*
 - *What are the implications for the satellite network?*
 - *What are the implications for the ad-hoc network?*
- Quality of service considerations
 - *Reliability of message delivery, especially for military systems*
 - *Network security*



Summary

- Communication satellite systems have unique strengths, design constraints
- Capacity and power of communication satellites have increased greatly over time
- Communication satellite applications have changed significantly over time
 - *Telephone relay*
 - *Video relay*
 - *Business applications*
 - *Broadcasting*
 - *Broadband delivery*
- Network aspects have become more sophisticated in the past decade

