

# Precisely controllable broadband frequency sweeps using a semiconductor laser in an optoelectronic phase-lock loop

Naresh Satyan,<sup>1,\*</sup> Arseny Vasilyev,<sup>2</sup> George Rakuljic,<sup>3</sup> Victor Leyva,<sup>1,4</sup> and Amnon Yariv<sup>1,2</sup>

<sup>1</sup>Department of Electrical Engineering, California Institute of Technology, 1200 E. California Blvd. 136-93, Pasadena, CA 91125 USA.

<sup>2</sup>Department of Applied Physics, California Institute of Technology, 1200 E. California Blvd. 128-95, Pasadena, CA 91125 USA.

<sup>3</sup>Telaris Inc., 2118 Wilshire Blvd. #238, Santa Monica, CA 90403 USA

<sup>4</sup>Current address: Raytheon Co., Space and Airborne Systems, 2000 E. El Segundo Blvd., El Segundo, CA 90245 USA  
\*[naresh@caltech.edu](mailto:naresh@caltech.edu)

**Abstract:** We demonstrate the generation of wideband frequency sweeps using a semiconductor laser in an optoelectronic phase-lock loop. The rate of the optical frequency sweep is locked to and determined by the frequency of a reference electronic signal, leading to an agile, high coherence swept-frequency source for laser ranging and 3-D imaging applications. Using a reference signal of constant frequency, a transform-limited linear sweep of 100 GHz in 1 ms is achieved, and real-time ranging with a spatial resolution of 1.5 mm is demonstrated. Further, arbitrary frequency sweeps can be achieved by tuning the frequency of the input electronic signal. Broadband quadratic and exponential optical frequency sweeps are demonstrated using this technique.

©2009 Optical Society of America

**OCIS Codes:** (140.3518) Lasers, frequency modulated; (140.3490) Lasers, distributed-feedback; (280.3640) Lidar

---

## References and links

1. M.-C. Amann, T. Bosch, M. Lescure, R. Myllyla and M. Rioux, "Laser ranging: a critical review of usual techniques for distance measurement," *Opt. Eng.* **40**, 10-19 (2001).
  2. J. Zheng, "Analysis of Optical Frequency-Modulated Continuous-Wave Interference," *Appl. Opt.* **43**, 4189-4198 (2004).
  3. W. S. Burdic, *Radar signal analysis* (Prentice-Hall, 1968), Chap. 5.
  4. G. Beheim and K. Fritsch, "Remote displacement measurements using a laser diode," *Electron. Lett.* **21**, 93-94 (1983).
  5. E. C. Burrows and K.-Y. Liou, "High-resolution laser LIDAR utilizing two-section distributed feedback semiconductor laser as a coherent source," *Electron. Lett.* **26**, 577-579 (1990).
  6. A. Dieckmann, "FMCW-LIDAR with tunable twin-guide laser diode," *Electron. Lett.* **30**, 308-309 (1994).
  7. E. M. Strzelecki, D. A. Cohen, and L. Coldren, "Investigation of tunable single frequency diode lasers for sensor applications," *J. Lightwave Technol.* **6**, 1610-1680 (1988).
  8. K. Iiyama, L.-T. Wang, and K. Hayashi, "Linearizing optical frequency-sweep of a laser diode for FMCW reflectometry," *J. Lightwave Technol.* **14**, 173-178 (1996).
  9. F. M. Gardner, *Phaselock Techniques* (Wiley 2005).
  10. N. Satyan, W. Liang and A. Yariv, "Coherence cloning using semiconductor laser optical phase-lock loops," *IEEE J. Quantum Elect.* (In press).
  11. I. V. Komarov and S. M. Smolskiy, *Fundamentals of short-range FM radar* (Artech House, 2003), Chap. 5.
- 

## 1. Introduction

Wideband optical swept frequency sources have applications in optical chirped radar and 3D imaging systems. In particular, the frequency modulated continuous wave (FMCW) optical

imaging technique is attractive for real-time high resolution imaging because of its large dynamic range [1,2]. The range resolution  $\delta z$  of an FMCW range measurement is determined by the total frequency excursion  $B$  of the optical source [3]

$$\delta z = \frac{c}{2B}, \quad (1)$$

where  $c$  is the speed of light. The key component of an FMCW imaging system is therefore a broadband and highly linear swept frequency source. The wide gain bandwidth of the semiconductor quantum well media, the narrow linewidth of a single mode semiconductor laser (SCL), and the ability to electronically control the lasing frequency using the injection current make the SCL an attractive candidate for a wideband swept-frequency source for FMCW imaging [4-7]. However, the bandwidth and the speed of demonstrated frequency sweeps have been limited by the inherent non-linearity of the frequency modulation response of the SCL vs. the injection current, especially at high speeds. A feedback system to overcome this nonlinearity using a fiber interferometer and a lock-in technique has been reported [8]; however the rate of the frequency sweep was limited to about 100 GHz in 10 ms.

In this paper, we report the development of an optoelectronic swept-frequency laser with precise control over the optical frequency sweep. The non-linearity of the SCL frequency-current response is overcome by a combination of two techniques – (i) an open-loop pre-distortion of the input current into the SCL, and (ii) an optoelectronic feedback loop in which the optical chirp rate is phase-locked to a reference electronic signal. When the system is in lock, the slope of the frequency deviation is determined by the frequency of the reference signal. Using a high coherence monochromatic reference oscillator, we demonstrate a rapid, highly linear frequency sweep of 100 GHz in 1 ms, which corresponds, using Eq. (1), to a range resolution of 1.5 mm. Further, the frequency of the reference signal can be varied dynamically to achieve arbitrary, time-varying optical frequency sweeps. We demonstrate quadratic and exponential sweeps of the frequency of the SCL by varying the frequency of the reference signal. Such an agile and precisely controllable broadband swept-frequency laser source also has potential applications in microwave photonics and Terahertz imaging and spectroscopy.

## 2. System description

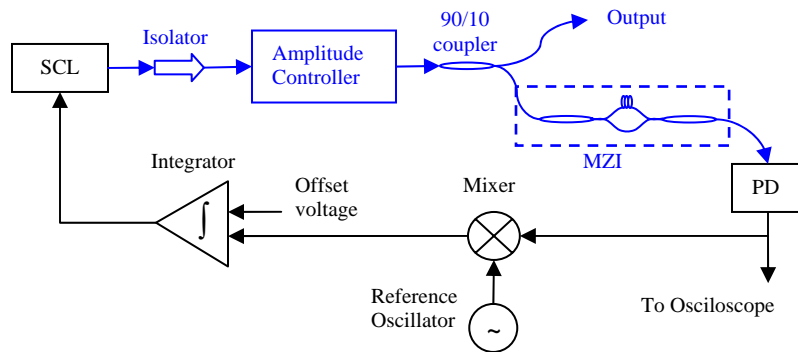

Fig. 1. Optoelectronic phase-lock loop for the generation of accurate broadband linear chirps. The optical path is shown in blue.

The feedback system for the generation of linear frequency chirps is shown in Fig. 1. A small part of the output of the swept SCL is coupled into the feedback loop using a 10/90 fiber coupler. The optical signal is passed through a fiber Mach-Zehnder Interferometer (MZI) with a differential time delay  $\tau$ , and is incident on a photodetector (PD). The output of the PD is mixed down using a reference signal of frequency  $\omega_R$ , integrated and is injected into the SCL. Since the injection current into the SCL also modulates the optical power, a low-speed

amplitude controller is used to maintain a constant output power. An offset voltage added to the integrator input is used to set the nominal optical frequency slope, and to provide an open-loop pre-distortion as described in Section 2.2.

The self-consistent solution of the control system is derived below. Let the laser frequency be given by

$$\omega_{SCL} = \omega_0 + \xi t, \quad (2)$$

where  $\xi$  is the slope of the optical frequency sweep. This corresponds to an optical phase

$$\phi(t) = \phi_0 + \omega_0 t + \frac{1}{2} \xi t^2. \quad (3)$$

The output of the photodetector PD is given by

$$i(t) = K_p \cos(\phi(t) - \phi(t - \tau)) = K_p \cos\left(\xi \tau t + \omega_0 \tau - \frac{\xi \tau^2}{2}\right) \quad (4)$$

where the PD gain  $K_p$  is the product of the optical power and the PD responsivity, and we have ignored the DC term in the PD output. Eq. (4) describes a sinusoidally varying signal with angular frequency  $\omega_{PD} = \xi \tau$ . If the frequency of the reference oscillator is chosen so that

$$\omega_R = \omega_{PD} = \xi \tau, \quad (5)$$

the output of the mixer is a DC signal whose value depends on the phase difference between the two mixer inputs, and the gains of the PD and the mixer. This DC current is amplified and integrated to provide a linear current to the laser, which in turn produces a frequency output as given by Eq. (2), thus providing a self-consistent steady-state solution. The frequency sweep is characterized by measuring the PD output; the frequency of the PD output is directly proportional to the optical sweep rate as given by Eq. (5).

The control system described above may also be regarded as a typical Phase-Lock Loop where the Voltage Controlled Oscillator (VCO) is replaced by the combination of the integrator, semiconductor laser, the MZI and the PD – the frequency of the PD output is proportional to the input voltage into the loop integrator. The slope of the laser output is therefore set by the electronic oscillator  $\omega_R$  as given by Eq. (5), and can be varied by using a VCO for the reference signal. The loop integrator is reset at the desired pulse repetition frequency (PRF) of the output chirped waveform.

### 2.1 Small signal analysis

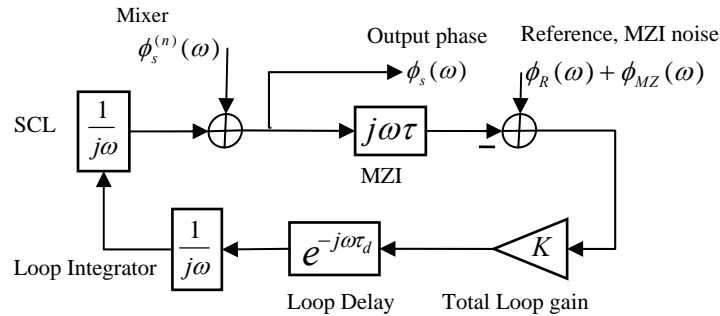

Fig. 2. Small signal phase propagation in the phase-lock loop.

The transient response of the system about the steady-state solution described by Eqs. (2)-(5) is studied in the Fourier domain using the small signal approximation as shown in Fig. 2. The variable in the loop is the Fourier transform of the deviation of the optical phase from its steady-state value in Eq. (3). For frequencies much smaller than its free spectral range, the MZI can be approximated as an ideal frequency discriminator.  $K$  denotes the total DC loop gain, given by the product of the gains of the laser, PD, mixer and the integrator. The phase noise of the laser and the noise introduced by the non-linearity of the frequency-vs.-current response of the SCL are together denoted by  $\phi_s^{(n)}(\omega)$ . The phase noise of the reference oscillator and the phase noise introduced by environmental fluctuations in the MZI are denoted by  $\phi_R(\omega)$  and  $\phi_{MZ}(\omega)$  respectively. Following a standard small-signal analysis [9], the output phase of the SCL is given by

$$\phi_s(\omega) = \phi_s^{(n)}(\omega) \frac{j\omega}{j\omega + K\tau e^{-j\omega\tau_d}} + (\phi_R(\omega) + \phi_{MZ}(\omega)) \frac{K\tau e^{-j\omega\tau_d}}{j\omega(j\omega + K\tau e^{-j\omega\tau_d})} \quad (6)$$

The non-linearity and laser phase noise within the loop bandwidth is corrected by the loop, as seen from the first term in Eq. (6). The frequency components of the non-linearity are of the order of the PRF of the waveform, and are therefore easily suppressed by the loop. The reduction in the phase noise of the SCL improves its coherence, leading to a higher signal-to-noise ratio in an FMCW interferometric experiment [10]. From the second term in Eq. (6), we see that the accuracy of the frequency chirp is dependent on the frequency stability of the VCO used as the reference signal, and on the stability of the MZI. It is possible to obtain very accurate linear frequency chirps with the use of ultra-low phase noise electronic oscillators and stabilized optical interferometers.

### 2.2 Pre-distortion of the SCL input current

The output frequency of the SCL varies nonlinearly with the injection current, and the resulting non-linearity in the frequency sweep can exceed the locking range of the optoelectronic phase-lock loop, especially at higher sweep rates. The sweep non-linearity can be reduced by pre-distorting the *open loop* input current to the SCL, as follows. The frequency of the SCL is related to the input sweep current according to

$$\omega(t) = \omega_0 + K_{SCL}(i) \cdot i(t), \quad (7)$$

where the nonlinearity of the modulation response is modeled by a current dependent gain  $K_{SCL}(i)$ . The frequency of the PD output is therefore given by

$$\begin{aligned} \omega_{PD}(t) &= \tau \frac{d\omega}{dt} = \frac{di}{dt} \cdot \left( \tau K_{SCL} + \tau i \frac{dK_{SCL}}{di} \right) \\ &= \frac{di}{dt} \cdot F_{dist}(i) \end{aligned} \quad (8)$$

A constant offset voltage is applied to the input of the integrator in Fig. 1, corresponding to a constant current ramp  $di/dt$ . The resultant PD frequency  $\omega_{PD}(t)$  is measured, and the distortion function  $F_{dist}(i)$  is extracted. This function is then used to solve Eq. (8) numerically, to obtain the pre-distortion current  $i_{pre}(t)$  that results in the desired  $\omega_{PD}(t)$ . The predistortion of the input current significantly reduces the non-linearity and enables phase-locking over a large frequency range, as seen in Section 3.1.

## 3. Experimental Demonstration

An experimental demonstration of the control system shown in Fig. 1 was performed using a commercially available fiber-coupled, narrow linewidth ( $< 1$  MHz at  $-3$  dB) DFB SCL with an output power of 40 mW at a wavelength of 1539 nm. Polarization maintaining fiber optic components were used in the loop. The free spectral range of the MZI was 35 MHz, corresponding to a delay of 28.6 ns. The optical sweep rate was characterized by measuring the spectrum of the detected photocurrent. It follows from Eq. (5) that a frequency of 2.86 MHz at the PD output corresponds to an optical sweep rate of  $10^{14}$  Hz/s, or a frequency excursion of 100 GHz in the designed pulse repetition period of 1 ms.

### 3.1 Linear frequency sweep

The measured spectrogram of the PD output when a constant voltage was applied to the integrator input is shown in Fig. 3(a). The resulting linear current input to the SCL produces an extremely non-linear frequency sweep. A time varying voltage, calculated as described in Section 2.2, was applied to the input of the loop integrator to reduce the non-linearity of the laser frequency modulation response. The variation of the sweep rate with time is significantly reduced with the application of the pre-distortion, as is evident from Fig. 3(b).

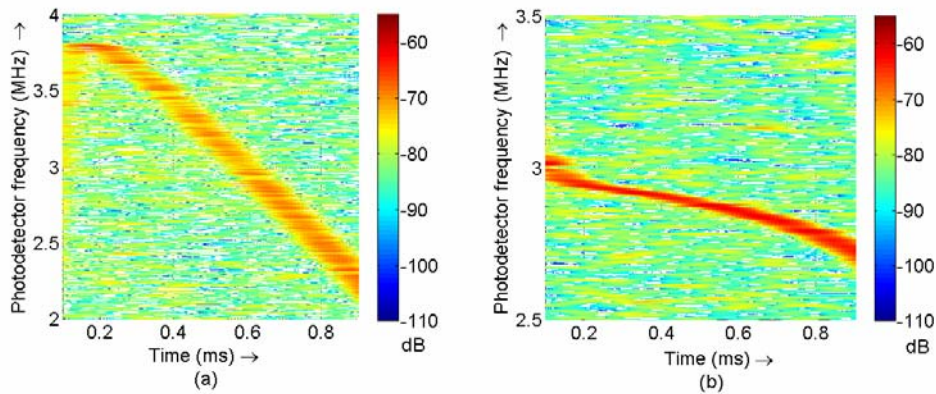

Fig. 3. Measured spectrograms of the output of the loop photodetector, for the (a) free-running and (b) pre-distorted cases. The pre-distortion significantly reduces the SCL non-linearity.

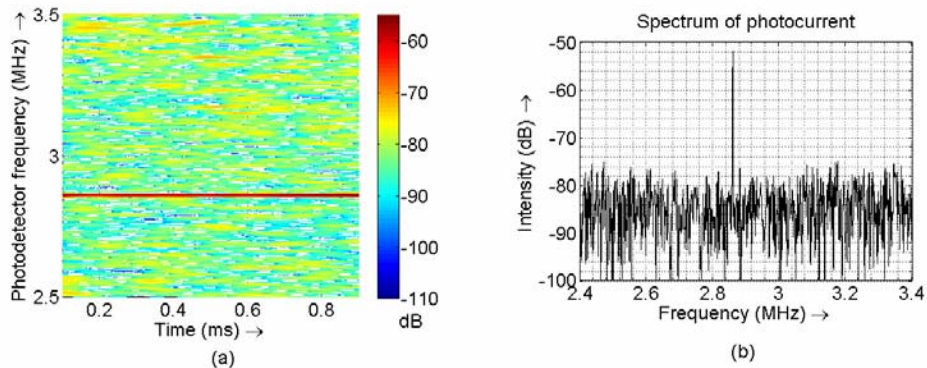

Fig.4. (a) Measured spectrogram of the output of the loop photodetector when the loop is in lock, corresponding to an optical sweep rate of 100 GHz/ms. (b) Fourier transform of the photodetector output measured over a 1 ms duration.

The pre-distorted frequency sweep was then locked to a high coherence external reference signal of frequency 2.86 MHz, to obtain a highly linear optical frequency sweep of 100 GHz

in 1 ms. The loop gain was adjusted by varying the amplitude of the reference signal. A loop bandwidth of  $\pm 200$  kHz was achieved. The spectrogram of the PD current when the loop is in lock is plotted in Fig. 4(a), showing that the rate of the optical frequency sweep remains constant with time. The Fourier transform of the PD current, shown in Fig 4(b), shows a narrow peak at the reference frequency of 2.86 MHz. The width of the peak is transform-limited to 1 kHz. The spectrum of the swept laser measured using an optical spectrum analyzer is shown in Fig. 5.

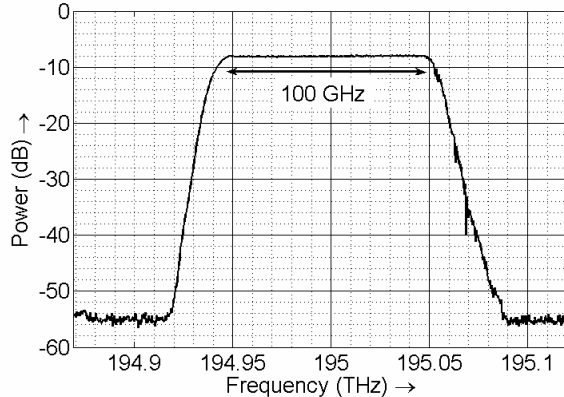

Fig. 5. Measured optical spectrum of the swept-frequency phase-locked SCL. RBW = 10 GHz

### 3.2 Range resolution measurement

The ability of the linearly swept SCL to resolve closely spaced targets was measured using the FMCW experimental setup shown in Fig. 6. Acrylic sheets of refractive index 1.5 and thicknesses varying from 1 mm to 6 mm were used as the target, and the reflections from the front and back surfaces were measured. A fiber delay line was used in the other arm of the interferometer to match the path lengths to about 1 m. The distance to the target was measured by computing the spectrum of the received photocurrent in real time using the FFT algorithm.

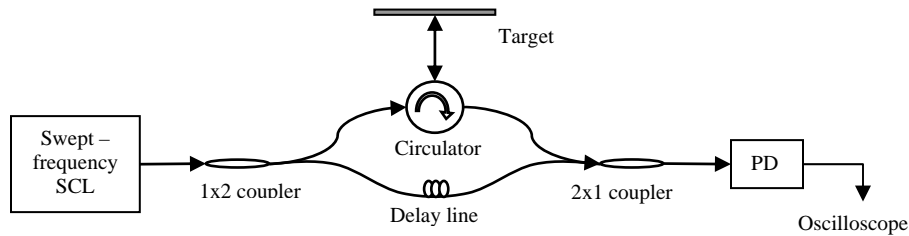

Fig. 6. Schematic of the ranging experiment with a linearly chirped optical source. PD: Photodetector

The results of the measurement are shown in Fig. 7. From Eq. (1), the minimum range resolution with a 100 GHz optical chirp is 1.5 mm in free space, or 1 mm in acrylic. As the separation between the reflections approaches the theoretical minimum resolution, the actual measured spectrum depends on the absolute distance to the target, and a practical resolution limit is 2 to 3 times the minimum resolution limit given by Eq. (1) [11]. We see from Fig. 7 that target separations of  $> \sim 1.5$  mm are resolved by the measurement. The low power second order reflection from the target is also detected, as seen in Figs. 7(a) and 7(b).

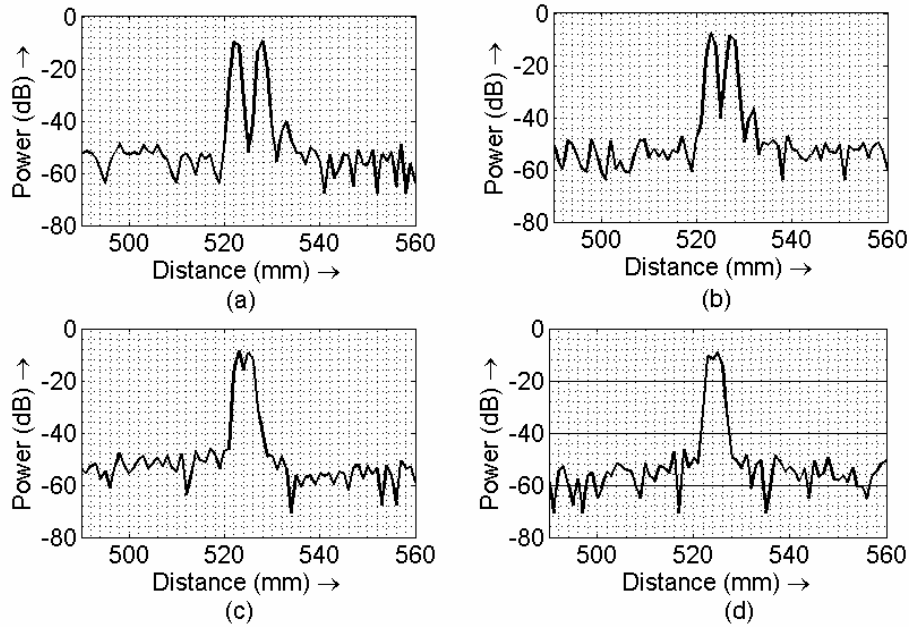

Fig. 7. Range resolution measurements using the swept-frequency SCL. The target was an acrylic sheet of refractive index 1.5 and thickness (a) 5.44 mm, (b) 4.29 mm, (c) 2.25 mm and (d) 1.49 mm.

### 3.3 Arbitrary frequency sweeps

The optoelectronic phase-lock loop technique can be extended to generate arbitrary frequency sweeps by the use of a voltage-controlled oscillator (VCO) as the reference signal. If the reference frequency  $\omega_R(t)$  is varied with time, the optical frequency is given by

$$\omega(t) = \frac{1}{\tau} \int_0^t \omega_R(t) dt, \quad (9)$$

where we have used Eq. (5) to relate the slope of the optical frequency to the reference frequency. This principle was demonstrated by the generation of quadratic and exponential optical frequency sweeps as shown in Figs. 8(a) and 8(b) respectively. In the former case, the reference frequency was varied linearly between 1.43 MHz and 4.29 MHz over 1 ms. This corresponds to a linear variation of the optical frequency slope from 50 GHz/ms to 150 GHz/ms, and consequently, a quadratic variation of the optical frequency. In the latter case, the reference frequency was varied exponentially between 4.29 MHz and 1.43 MHz according to the relation

$$f_R(t) = (4.29 \text{ MHz}) \cdot \left( \frac{1.43 \text{ MHz}}{4.29 \text{ MHz}} \right)^{t/(1 \text{ ms})} \quad (10)$$

This corresponds to an exponential decrease of the slope of the optical frequency from 150 GHz/ms to 50 GHz/ms over 1 ms. A pre-distortion was applied to the integrator input in both cases, as described in Section 2.2. The measured slope of the optical frequency sweep shown in Fig. 8 is identical to the temporal variation of the frequency of the reference signal. By pre-distorting the SCL current to produce the nominal output frequency sweep, this phase-lock technique can be applied to generate any desired shape of the optical sweep.

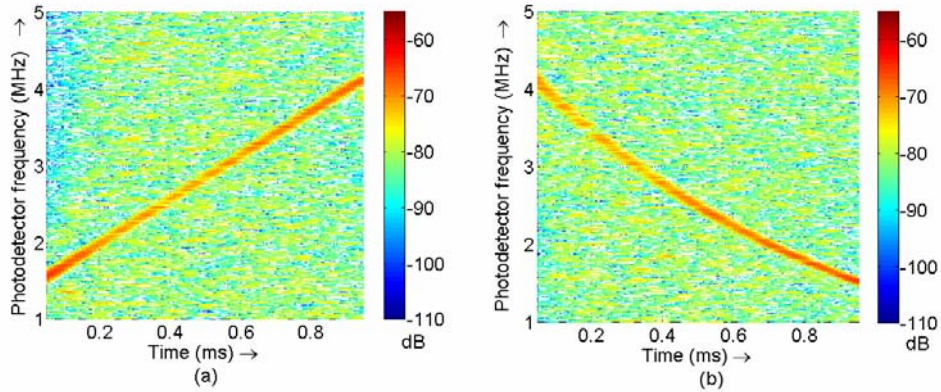

Fig.8. Measured spectrograms of the output of the loop photodetector, illustrating arbitrary sweeps of the SCL frequency. (a) The reference signal is swept linearly with time. (b) The reference signal is swept exponentially with time. The laser sweep rate varies between 50 GHz/ms and 150 GHz/ms.

#### 4. Summary

We have demonstrated the generation of accurate and broadband frequency sweeps of a SCL using a combination of laser current pre-distortion and an optoelectronic phase-lock loop. The rate of the optical frequency sweep is locked to and determined by the frequency of an external reference signal. The closed loop control system also reduces the inherent phase noise of the SCL within the loop bandwidth, thereby enabling coherent interferometry at larger distances. We have demonstrated a highly linear frequency sweep of 100 GHz in 1 ms using this approach, corresponding to an experimentally measured FMCW range resolution of  $< 1.5$  mm. Further, we have demonstrated the generation of very precise arbitrary broadband frequency sweeps by varying the frequency of the external reference signal.

The range of the frequency sweep in the experimental demonstration was limited by the tuning range of the DFB laser. With the use of SCLs with large tuning ranges, such as Vertical Cavity Surface Emitting Lasers (VCSELs), this approach can be extended to achieve frequency sweeps of a few THz. The speed of frequency tuning is only limited by the ability of the pre-distortion to reduce the non-linearity to within the loop bandwidth, and we anticipate that tuning speeds larger than  $10^{16}$  Hz/s are achievable using this technique.

#### 5. Acknowledgement

This work was supported in part by the Caltech Lee Center for Advanced Networking.